

Shaft support blocks

**Shaft support block, R1056
Flanged**

Material

- Lamellar graphite cast iron

Design

- Compared to installing the shafts in customer-made bores, flanged shaft support blocks allow the shafts to be aligned and prevent the linear bushings from overloading due to shafts that are not parallel
- Side clamping screw



Shaft Ø d (mm)	Material number WBG-...F	Weight (kg)
12	R1056 012 00	0.15
16	R1056 016 00	0.21
20	R1056 020 00	0.28
25	R1056 025 00	0.41
30	R1056 030 00	0.75
40	R1056 040 00	1.65
50	R1056 050 00	2.60

Dimensions

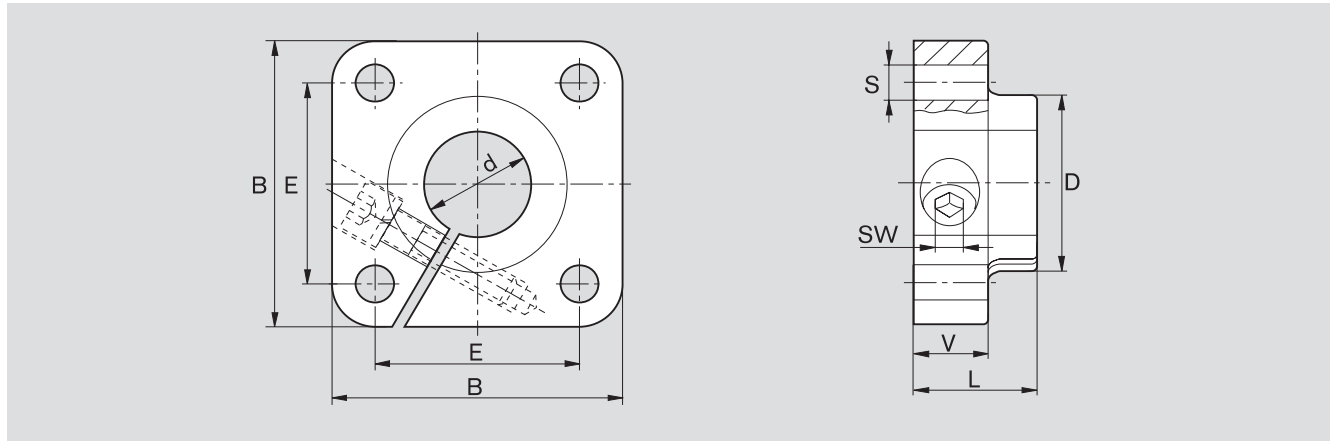

Dimensions (mm)									
Ø d	d H7	B ¹⁾	L ¹⁾	D ¹⁾	E	S H13	V ¹⁾	SW	
12	12	42	20	23.5	30±0.12	5.5	12	3	
16	16	50	20	27.5	35±0.12	5.5	12	3	
20	20	54	23	33.5	38±0.15	6.6	14	4	
25	25	60	25	42.0	42±0.15	6.6	16	5	
30	30	76	30	49.5	54±0.25	9.0	19	6	
40	40	96	40	65.0	68±0.25	11.0	26	8	
50	50	106	50	75.0	75±0.25	11.0	36	8	

1) ISO 8062-3 - DCTG 9 tolerance

Explanation of sample short product name

WB	G	20	-	F
Shaft support block	Lamellar graphite cast iron	Ø 20		Flanged

See page 236 for more information on short product names.