

Standard linear bushings

**Standard linear bushings,  
R0600 closed, no wiper seals**

**Standard linear bushings,  
R0602 closed, with wiper seals**

**Design**

- Hardened and machined outer sleeve
- Steel ball retainer (shaft diameters 3 to 10 with plastic ball retainer made of POM<sup>1)</sup> or PA<sup>2)</sup>)
- Balls made of rolling bearing steel
- No wiper seals, come with integrated steel retaining rings; higher temperatures allowed with shaft diameters 12 and higher
- Integrated wiper seals for high contamination
- Closed, for self-supporting shafts



Shaft Ø d (mm)	Material number		Weight (kg)
	No wiper seal KBM- ...	With two wiper seals KBM- ... -DD	
3 <sup>1)</sup>	R0600 303 00	-	0.001
4 <sup>1)</sup>	R0600 304 00	-	0.002
5 <sup>2)</sup>	R0600 305 00	R0602 305 10	0.010
8 <sup>2)</sup>	R0600 308 00	R0602 308 10	0.020
10 <sup>1)</sup>	R0600 310 00	R0602 310 10	0.030
12	R0600 012 00	R0602 012 10	0.040
16	R0600 016 00	R0602 016 10	0.050
20	R0600 020 00	R0602 020 10	0.100
25	R0600 025 00	R0602 025 10	0.190
30	R0600 030 00	R0602 030 10	0.320
40	R0600 040 00	R0602 040 10	0.620
50	R0600 050 00	R0602 050 10	1.140
60	R0600 060 00	R0602 060 10	2.110
80	R0600 080 00	R0602 080 10	4.700

With 1 wiper seal: R0601 ... 10.

**Explanation of sample short product name**

KB	M	12	DD
Linear bushing	Standard (metal)	Ø 12	With two seals

See page 96 for more information on short product names.

Dimensions

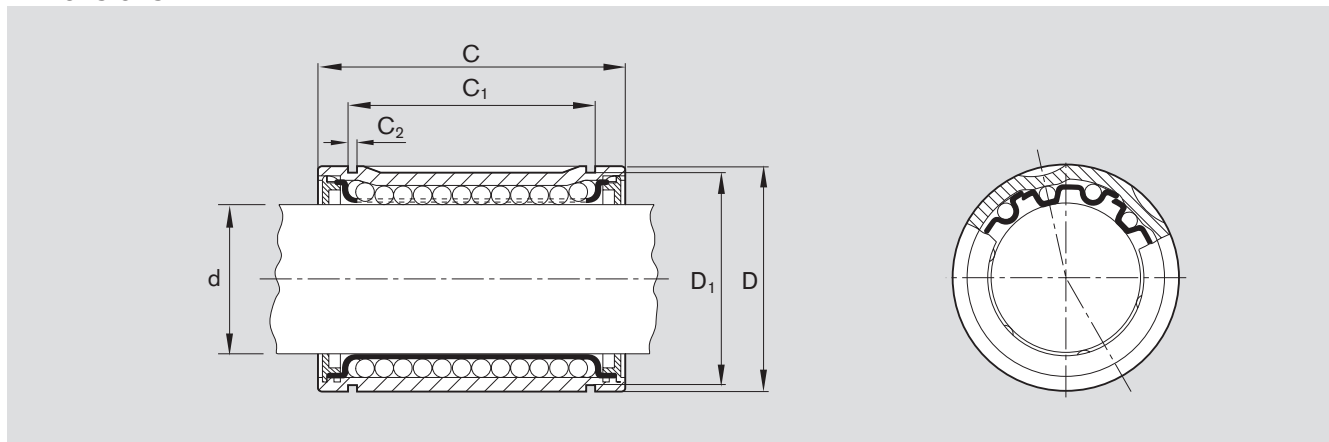

Dimensions (mm)						Rows of balls	Working bore diameter tolerance (µm)	Radial clearance <sup>1)</sup> h6 shaft (µm)	Load ratings (N)			
Ø d	D	C h12	C <sub>1</sub> H13	C <sub>2</sub>	D <sub>1</sub>				min.	dyn. C max.	min.	stat. C <sub>0</sub> max.
3	7	10	-	-	-	4	+8 0	+12 +2	55	65	45	65
4	8	12	-	-	-	4	+8 0	+14 +2	70	80	60	85
5	12	22	14.2	1.1	11.1	4	+11 +1	+16 +4	180	210	140	200
8	16	25	16.2	1.1	14.7	4	+12 +2	+18 +5	320	370	240	330
10	19	29	21.6	1.3	18.0	4	+8 0	+18 +5	300	350	260	370
12	22	32	22.6	1.3	20.5	4	+12 +2	+20 +5	420	480	280	400
16	26	36	24.6	1.3	24.9	4	+14 +2	+22 +5	580	670	440	620
20	32	45	31.2	1.6	30.5	5	+14 +2	+23 +6	1,170	1,390	860	1,250
25	40	58	43.7	1.85	38.5	5	+16 +2	+25 +6	2,080	2,480	1,560	2,280
30	47	68	51.7	1.85	44.5	6	+16 +2	+25 +6	2,820	2,980	2,230	2,860
40	62	80	60.3	2.15	58.0	6	+19 +2	+30 +7	5,170	5,480	3,810	4,880
50	75	100	77.3	2.65	71.0	6	+19 +2	+30 +7	8,260	8,740	6,470	8,280
60	90	125	101.3	3.15	85.0	6	+19 +2	+33 +7	11,500	12,100	9,160	11,730
80	120	165	133.3	4.15	114.0	6	+24 +2	+37 +8	21,000	22,200	16,300	20,850

1) Determined from working bore diameter and shaft tolerance statistics. Recommended housing bore tolerance: H6 or H7.

The dynamic load ratings are based on a total travel of 100,000 m.  
When based on 50,000 m, the C values in the table are multiplied by 1.26.

Standard linear bushings

### Standard linear bushings, R0600 Closed, no wiper seal stainless

### Standard linear bushings, R0602 Closed, with wiper seals stainless

#### Design

- Hardened and machined outer sleeve made of stainless steel comparable to 1.4125
- Ball retainer made of stainless steel comparable to 1.4301
- Balls made of stainless steel comparable to 1.4125
- Integrated retaining rings made of stainless steel comparable to 1.4006 or wiper seals
- Closed, for self-supporting shafts

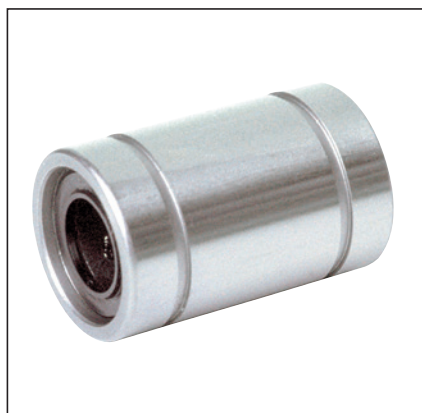

Shaft Ø d (mm)	Material number		Weight (kg)
	No wiper seal KBM- ... -NR	With two wiper seals KBM- ... -DD-NR	
3	R0600 003 30	–	0.001
4	R0600 004 30	–	0.002
5	R0600 005 30	R0602 005 30	0.011
8	R0600 008 30	R0602 008 30	0.022
10	R0600 010 30	R0602 010 30	0.036
12	R0600 012 30	R0602 012 30	0.045
16	R0600 016 30	R0602 016 30	0.060
20	R0600 020 30	R0602 020 30	0.100
25	R0600 025 30	R0602 025 30	0.235
30	R0600 030 30	R0602 030 30	0.360
40	R0600 040 30	R0602 040 30	0.770

#### Explanation of sample short product name

KB	M	12	DD	NR
Linear bushing	Standard (metal)	Ø 12	With two seals	Stainless steel

See page 96 for more information on short product names.