

Standard linear bushings

**Standard linear bushings,  
R0630 Open, no wiper seals**

**Standard linear bushings,  
R0632 Open, with wiper seals**

**Design**

- Hardened and machined outer sleeve
- Steel ball retainer
- Balls made of rolling bearing steel
- No wiper seals, come with integrated steel retaining rings; higher temperatures allowed with shaft diameters 12 and higher
- Integrated wiper seals for high contamination
- With locating hole for axial and radial securing (no locating hole for shaft diameters 12 and 16)



Shaft Ø d (mm)	Material number			Weight (kg)
	No wiper seal KBM-O- ...	2 wiper seals KBM-O- ... -DD	Fully sealed KBM-O- ... -VD	
12 <sup>1)</sup>	R0630 012 00	R0632 012 00	-	0.03
16 <sup>1)</sup>	R0630 016 00	R0632 016 00	-	0.04
20	R0630 020 00	R0632 020 00	R0632 020 05	0.08
25	R0630 025 00	R0632 025 00	R0632 025 05	0.15
30	R0630 030 00	R0632 030 00	R0632 030 05	0.26
40	R0630 040 00	R0632 040 00	R0632 040 05	0.52
50	R0630 050 00	R0632 050 00	R0632 050 05	0.95
60	R0630 060 00	R0632 060 00	R0632 060 05	1.76
80	R0630 080 00	R0632 080 00	R0632 080 05	3.92

1) No locating hole for radial and axial securing.

With 1 wiper seal: R0631 0.. 00.

**Explanation of sample short product name**

KB	M	O	12	DD
Linear bushing	Standard (metal)	Open	Ø 12	With two seals

See page 96 for more information on short product names.

Dimensions

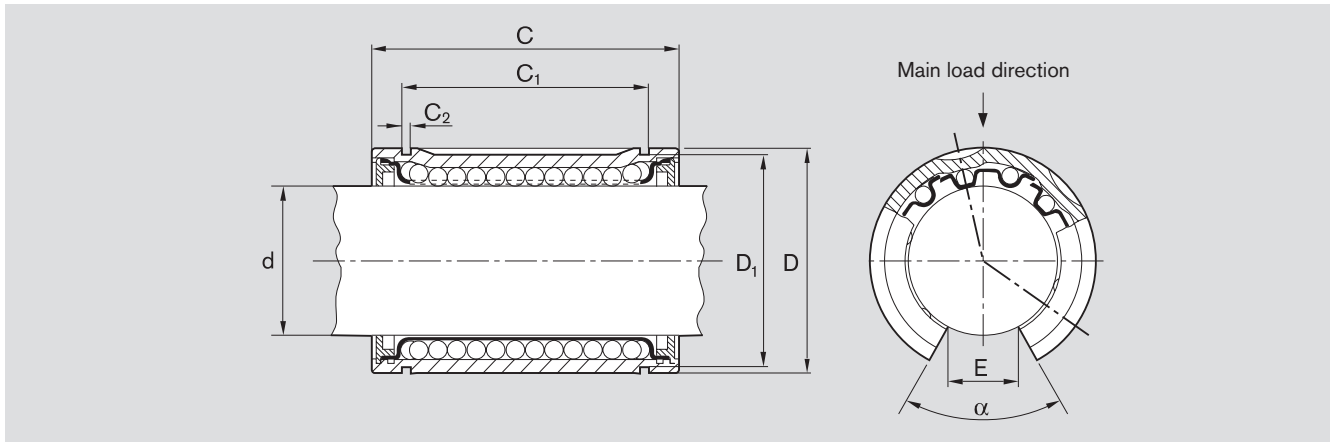

Dimensions (mm)							Angle $\alpha$ (°)	Rows of balls	Load ratings <sup>2)</sup> (N)		Radial clearance ( $\mu\text{m}$ )	
$\varnothing d$	D	C h12	C <sub>1</sub> H13	C <sub>2</sub>	D <sub>1</sub>	E <sup>1)</sup>			dyn. C	stat. C <sub>0</sub>	Shaft/bore h6/H7	h6/K7
12	22	32	22.6	1.30	20.5	7.5	78	3	430	290	+41 +14	+26 -1
16	26	36	24.6	1.30	24.9	10.0	78	3	600	450	+43 +14	+28 -1
20	32	45	31.2	1.60	30.5	10.0	60	4	1,280	970	+49 +16	+31 -2
25	40	58	43.7	1.85	38.5	12.5	60	4	2,270	1,750	+50 +17	+32 -1
30	47	68	51.7	1.85	44.5	12.5	50	5	2,890	2,390	+50 +17	+32 -1
40	62	80	60.3	2.15	58.0	16.8	50	5	5,280	4,000	+60 +20	+39 -1
50	75	100	77.3	2.65	71.0	21.0	50	5	8,470	6,900	+60 +20	+39 -1
60	90	125	101.3	3.15	85.0	27.2	54	5	11,800	9,780	+68 +22	+43 -3
80	120	165	133.3	4.15	114.0	36.3	54	5	21,500	17,400	+71 +24	+46 -1

- 1) Minimum size in relation to  $\varnothing d$ .
- 2) The load ratings C and C<sub>0</sub> apply for the main load direction.

The dynamic load ratings are based on a total travel of 100,000 m.  
When based on 50,000 m, the C values in the table are multiplied by 1.26.

**⚠** Refer to the diagrams on page 99 for load in the direction of opening.

Shaft diameters 12 and 16 must be installed as shown (inversely) in order to avoid lifting off the shaft. It is not possible to set a single linear bushing (slotted housing with adjusting screw) to zero clearance.

