

Super linear bushings 

Super linear bushings, R0732
Closed

Super linear bushings, R0733
Open

Design



- POM ball retainer
- Hardened steel bearing plates with machined ball guide grooves and machined back
- Balls made of rolling bearing steel

- Compensate for misalignments of up to 30 ft
- Two metal retaining rings
- Optional double-lipped wiper seals

- Optional linear seal



See "Technical data – Load direction factors" for exact values for the 4 main load directions.



Shaft Ø d (mm)	Material number		Hollow bolt ¹⁾	Locating screw ²⁾	Weight (kg)
	No Wiper seal KBH- ...	2 wiper seals KBH- ... -DD			
20	R0732 020 00	R0732 220 40	R3432 010 00	R3427 008 09	0.070
25	R0732 025 00	R0732 225 40	R3432 007 00	R3427 003 09	0.150
30	R0732 030 00	R0732 230 40	R3432 007 00	R3427 003 09	0.210
40	R0732 040 00	R0732 240 40	R3432 007 00	R3427 003 09	0.400
50	R0732 050 00	R0732 250 40	R3432 008 00	R3427 004 09	0.700
60	R0732 060 00	R0732 260 40	R3432 009 00	R3427 007 09	1.200
					

1 wiper seal: R0732 1 ... 40 or R0733 1 ... 40



Shaft Ø d (mm)	Material number			Locating screw ²⁾	Weight (kg)
	No Wiper seal KBH-O- ...	2 wiper seals KBH-O- ... DD	Fully sealed KBH-O- ... VD		
20	R0733 020 00	R0733 220 40	R0733 220 45	R3427 008 09	0.060
25	R0733 025 00	R0733 225 40	R0733 225 45	R3427 003 09	0.130
30	R0733 030 00	R0733 230 40	R0733 230 45	R3427 003 09	0.180
40	R0733 040 00	R0733 240 40	R0733 240 45	R3427 003 09	0.350
50	R0733 050 00	R0733 250 40	R0733 250 45	R3427 004 09	0.600
60	R0733 060 00	R0733 260 40	R0733 260 45	R3427 007 09	1.000
					

1) See page 81 for dimensions

2) See page 82 for dimensions

Explanation of sample short product name

KB	H	O	20	DD
Linear bushing	Super 	Open	Ø 20	Two seals

See page 74 for more information on short product names.

Dimensions

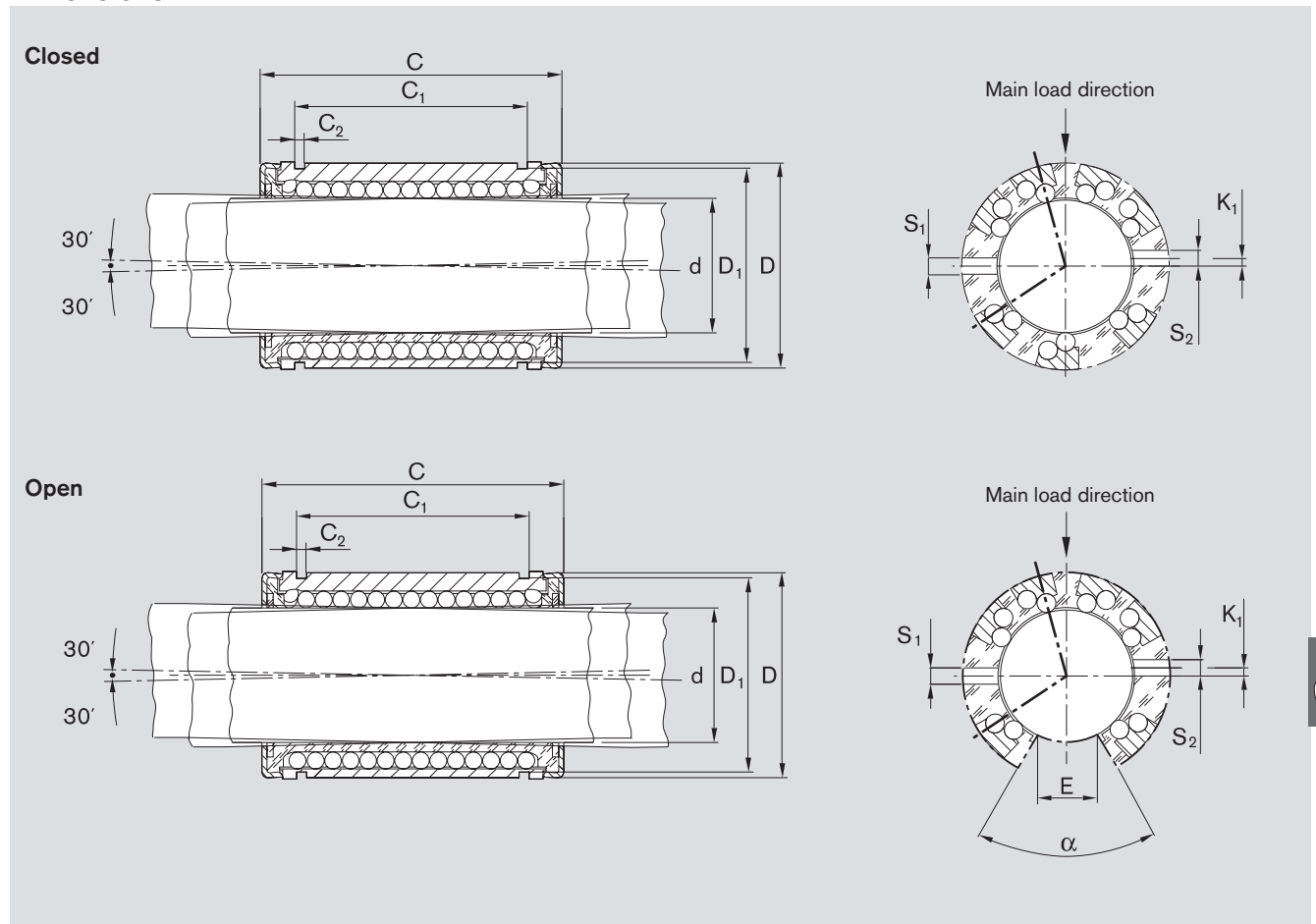

Dimensions (mm)										Rows of balls		Angle α (°)	Radial clearance (μm)			Load ratings ²⁾ (N)	
$\varnothing d$	D	C h13	C ₁ H13	C ₂	D ₁	S ₁ ¹⁾ +0.1	S ₂ ¹⁾ +0.1	K ₁	E ²⁾				Shaft/bore h6/H7	h6/K7	h6/M7	dyn. C	stat. C ₀
20	32	45	31.2	1.6	30.5	3.0	-	-	9.5	7	6	+43 +11	+25 -7	+18 -14	2,520	1,880	
25	40	58	43.7	1.85	38.5	3.5	3	-1.5	12.0	7	6	+43 +11	+25 -7	+18 -14	4,430	3,360	
30	47	68	51.7	1.85	44.5	3.5	3	2.0	12.8	7	6	+43 +11	+25 -7	+18 -14	6,300	5,230	
40	62	80	60.3	2.15	59.0	3.5	3	1.5	16.8	7	6	+50 +12	+29 -7	+20 -18	9,680	7,600	
50	75	100	77.3	2.65	72.0	4.5	5	2.5	22.1	7	6	+50 +12	+29 -7	+20 -18	16,000	12,200	
60	90	125	101.3	3.15	86.5	6.0	-	-	27.0	7	6	+56 +14	+31 -11	+21 -21	23,500	18,700	

- 1) Holes at center of dimension C
- 2) Minimum size in relation to $\varnothing d$
- 3) The load ratings apply for the main load direction

The dynamic load ratings are based on a total travel of 100,000 m.
When based on 50,000 m, the C values in the table are multiplied by 1.26.

⚠ Refer to the diagrams on page 78 for load in the direction of opening.