

Super linear bushings 

Super linear bushing without misalignment compensation

Super linear bushings, R0672
Closed

Super linear bushings, R0673
Open

Design

- Ball retainer and outer sleeve made of PA or POM
- Hardened steel bearing plates with machined ball guide grooves
- Balls made of rolling bearing steel
- No wiper seal
- Integrated wiper seals
- No initial lubrication

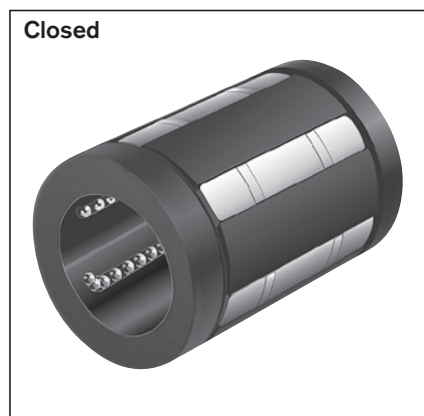

Shaft Ø d (mm)	Material number		Weight (kg)
	No wiper seal KBB- ...	With two integrated wiper seals KBB- ... -DD	
10	R0672 010 00	R0672 210 40	0.017
12	R0672 012 00	R0672 212 40	0.023
16	R0672 016 00	R0672 216 40	0.028
20	R0672 020 00	R0672 220 40	0.061
25	R0672 025 00	R0672 225 40	0.122
30	R0672 030 00	R0672 230 40	0.185
40	R0672 040 00	R0672 240 40	0.360
50	R0672 050 00	R0672 250 40	0.580

With an integrated wiper seal: R0672 1 ... 40.



Shaft Ø d (mm)	Material number			Weight (kg)
	No wiper seal KBB-O- ...	With two integrated wiper seals KBB-O- ... -DD	With two integrated wiper seals and linear seal KBB-O- ... -VD	
12	R0673 012 00	R0673 212 40	R0673 212 45	0.018
16	R0673 016 00	R0673 216 40	R0673 216 45	0.022
20	R0673 020 00	R0673 220 40	R0673 220 45	0.051
25	R0673 025 00	R0673 225 40	R0673 225 45	0.102
30	R0673 030 00	R0673 230 40	R0673 230 45	0.155
40	R0673 040 00	R0673 240 40	R0673 240 45	0.300
50	R0673 050 00	R0673 250 40	R0673 250 45	0.480

With an integrated wiper seal: R0673 1 ... 40.

See Section "Customer-built housing" for separate wiper seals.

The dynamic load ratings are based on a total travel of 100,000 m.
When based on 50,000 m, the C values in the table are multiplied by 1.26.

Explanation of sample short product name

KB	B	O	20	DD
Linear bushing	Super 	Open	Ø 20	Two seals

See page 38 for more information on short product names.

Dimensions

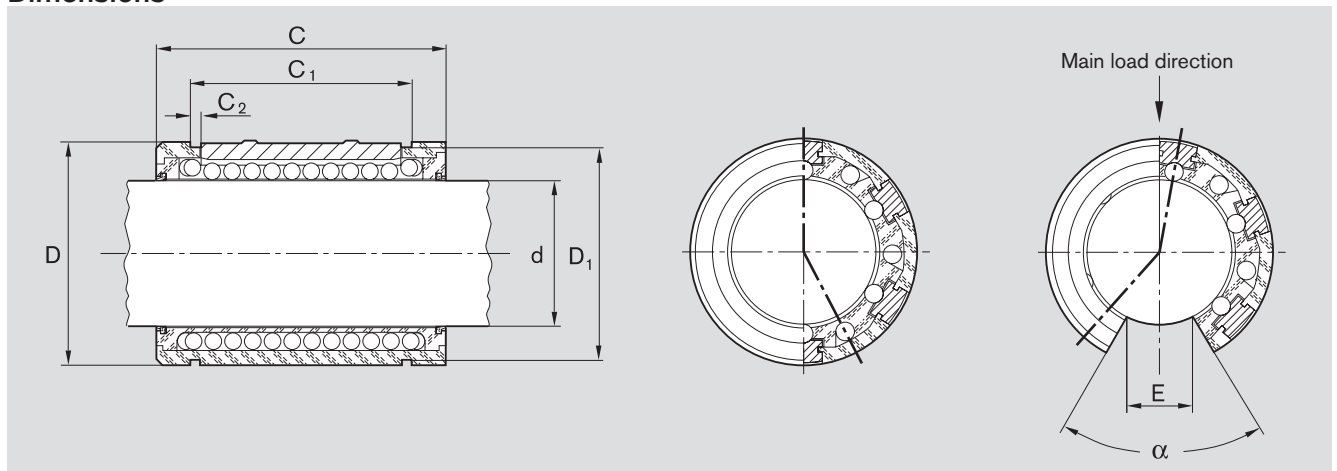

Closed

Dimensions (mm)						Rows of balls	Radial clearance (µm) Shaft/bore			Load ratings (N)			
Ø d	D	C h13	C ₁ H13	C ₂	D ₁		h6/H7	h6/K7	h6/M7	min.	dyn. C max.	min.	stat. C ₀ max.
10	19	29	21.6	1.3	18.0	5	+9 +36	+21 -6	+15 -12	600	820	330	480
12	22	32	22.6	1.3	21.0	5	+38 +10	+23 -5	+17 -11	830	1,140	420	620
16	26	36	24.6	1.3	24.9	5	+38 +10	+23 -5	+17 -11	1,020	1,400	530	780
20	32	45	31.2	1.6	30.5	6	+43 +11	+25 -7	+18 -14	2,020	2,470	1,050	1,340
25	40	58	43.7	1.85	38.5	6	+43 +11	+25 -7	+18 -14	3,950	4,820	2,180	2,790
30	47	68	51.7	1.85	44.5	6	+43 +11	+25 -7	+18 -14	4,800	5,860	2,790	3,570
40	62	80	60.3	2.15	58.5	6	+50 +12	+29 -9	+20 -18	8,240	10,070	4,350	5,570
50	75	100	77.3	2.65	71.5	6	+50 +12	+29 -9	+20 -18	12,060	14,730	6,470	8,280

Open

Dimensions (mm)						Angle α (°)	Rows of balls	Radial clearance (µm) Shaft/bore			Load ratings ²⁾ (N)	
Ø d	D	C h13	C ₁ H13	C ₂	E ¹⁾			h6/H7	h6/K7	h6/M7	dyn. C	stat. C ₀
12	22	32	22.6	1.3	6.5	66	4	+38 +10	+23 -5	+17 -11	1,060	510
16	26	36	24.6	1.3	9.0	68	4	+38 +10	+23 -5	+17 -11	1,500	830
20	32	45	31.2	1.6	9.0	55	5	+43 +11	+25 -7	+18 -14	2,570	1,180
25	40	58	43.7	1.85	11.5	57	5	+43 +11	+25 -7	+18 -14	5,040	2,770
30	47	68	51.7	1.85	14.0	57	5	+43 +11	+25 -7	+18 -14	5,020	2,880
40	62	80	60.3	2.15	19.5	56	5	+50 +12	+29 -9	+20 -18	8,620	4,480
50	75	100	77.3	2.65	22.5	54	5	+50 +12	+29 -9	+20 -18	12,500	6,620

⚠ Refer to the diagrams on page 41 for load in the direction of opening.

- 1) Minimum size in relation to Ø d
- 2) The load ratings apply for the main load direction.