

FLS – Flange, long, standard height R1653 ... 2.

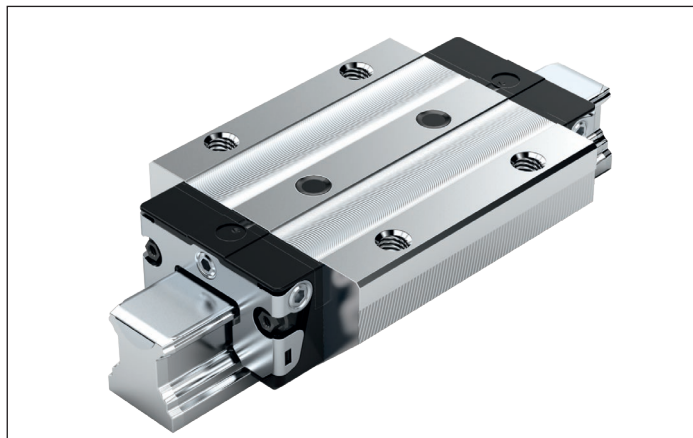

Dynamic characteristics

Speed: $v_{max} = 5 \text{ m/s}$
 Acceleration: $a_{max} = 500 \text{ m/s}^2$
 (If $F_{comb} > 2.8 \cdot F_{pr}$: $a_{max} = 50 \text{ m/s}^2$)

Note on lubrication

► Pre-lubricated

Note

Can be used on all SNS/SNO ball guide rails. Ball runner blocks of size 55 and size 65 can be found in chapter "Heavy-duty ball runner block BSHP made of steel" after this chapter.

Options and material numbers

Size	Ball runner block with size	Preload class				Accuracy class						Seal on ball runner block					
		C0	C1	C2	C3	N	H	P	XP	SP	UP	without ball chain			with ball chain		
												SS	LS ¹⁾	DS	SS	LS ¹⁾	DS
15	R1653 1	9				4	3	-	-	-	-	20	21	-	22	23	-
			1			4	3	2	8	1	9	20	21	2Z	22	23	2Y
				2		-	3	2	8	1	9	20	21	2Z	22	23	2Y
					3	-	-	-	8	1	9	20	21	2Z	22	23	2Y
20	R1653 8	9				4	3	-	-	-	-	20	21	-	22	23	-
			1			4	3	2	8	1	9	20	21	2Z	22	23	2Y
				2		-	3	2	8	1	9	20	21	2Z	22	23	2Y
					3	-	-	-	8	1	9	20	21	2Z	22	23	2Y
25	R1653 2	9				4	3	-	-	-	-	20	21	-	22	23	-
			1			4	3	2	8	1	9	20	21	2Z	22	23	2Y
				2		-	3	2	8	1	9	20	21	2Z	22	23	2Y
					3	-	-	-	8	1	9	20	21	2Z	22	23	2Y
30	R1653 7	9				4	3	-	-	-	-	20	21	-	22	23	-
			1			4	3	2	8	1	9	20	21	2Z	22	23	2Y
				2		-	3	2	8	1	9	20	21	2Z	22	23	2Y
					3	-	-	-	8	1	9	20	21	2Z	22	23	2Y
35	R1653 3	9				4	3	-	-	-	-	20	21	-	22	23	-
			1			4	3	2	8	1	9	20	21	2Z	22	23	2Y
				2		-	3	2	8	1	9	20	21	2Z	22	23	2Y
					3	-	-	-	8	1	9	20	21	2Z	22	23	2Y
45	R1653 4	9				4	3	-	-	-	-	20	-	-	22	-	-
			1			4	3	2	8	1	9	20	-	2Z	22	-	2Y
				2		-	3	2	8	1	9	20	-	2Z	22	-	2Y
					3	-	-	-	8	1	9	20	-	2Z	22	-	2Y
E.g.:	R1653 7		1				3										20

1) Only for accuracy classes N and H and for XP in preload class C1.

Ordering example

Options:

- Ball runner block FLS
- Size 30
- Preload class C1
- Accuracy class H
- With standard seal, without ball chain

Material number:

R1653 713 20

Preload classes

C0 = Without preload (clearance)
 C1 = Moderate preload
 C2 = Average preload
 C3 = High preload

Seals

SS = Standard seal
 LS = Low-friction seal
 DS = Double-lip seal

Key

gray numbers
 = no preferred variant / combination
 (partially longer delivery times)

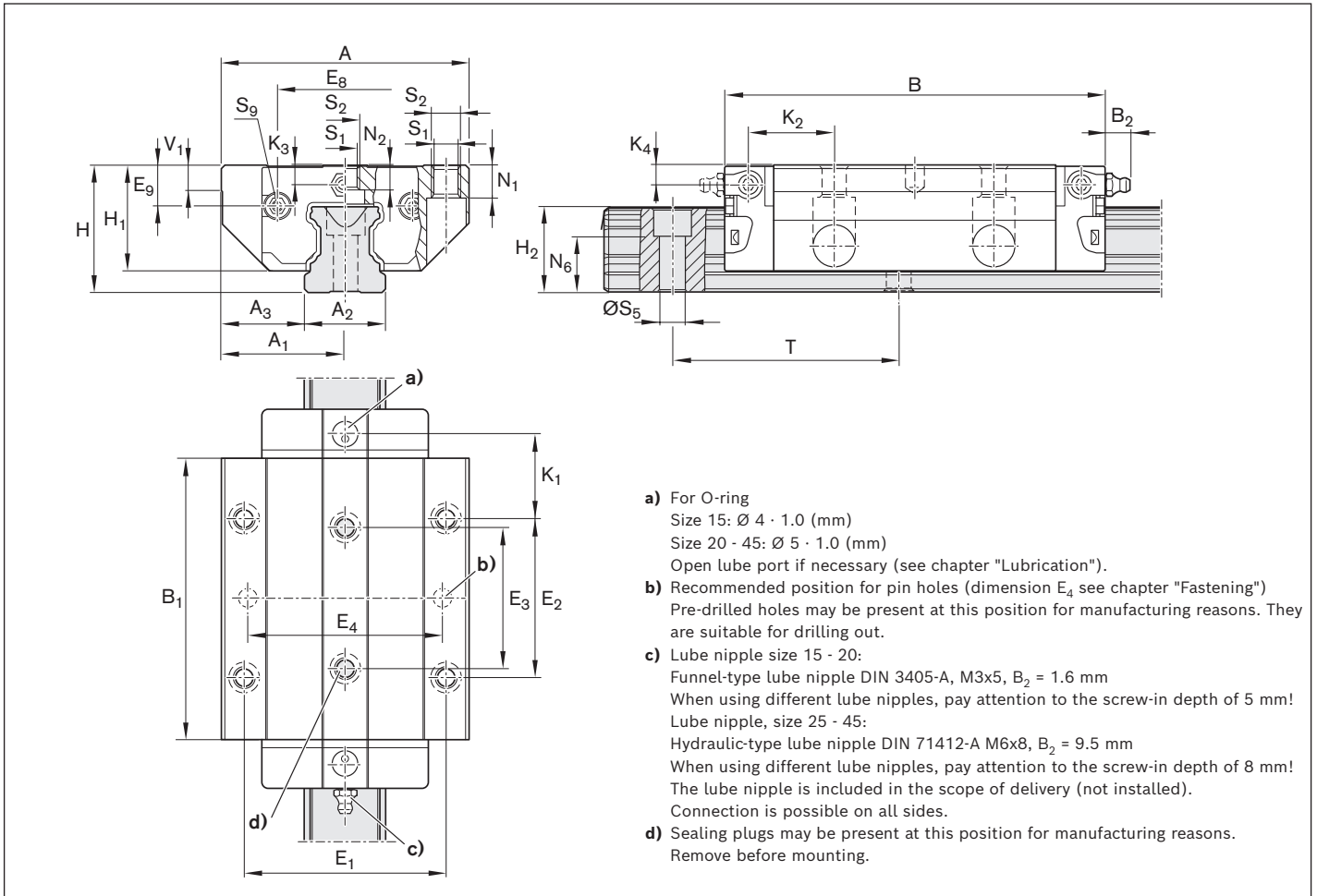

- a) For O-ring
 Size 15: Ø 4 · 1.0 (mm)
 Size 20 - 45: Ø 5 · 1.0 (mm)
 Open lube port if necessary (see chapter "Lubrication").
- b) Recommended position for pin holes (dimension E₄ see chapter "Fastening")
 Pre-drilled holes may be present at this position for manufacturing reasons. They are suitable for drilling out.
- c) Lube nipple size 15 - 20:
 Funnel-type lube nipple DIN 3405-A, M3x5, B₂ = 1.6 mm
 When using different lube nipples, pay attention to the screw-in depth of 5 mm!
 Lube nipple, size 25 - 45:
 Hydraulic-type lube nipple DIN 71412-A M6x8, B₂ = 9.5 mm
 When using different lube nipples, pay attention to the screw-in depth of 8 mm!
 The lube nipple is included in the scope of delivery (not installed).
 Connection is possible on all sides.
- d) Sealing plugs may be present at this position for manufacturing reasons.
 Remove before mounting.

Size	Dimensions (mm)																		
	A	A ₁	A ₂	A ₃	B ^{+0.5}	B ₁	E ₁	E ₂	E ₃	E ₈	E ₉	H	H ₁	H ₂ ¹⁾	H ₂ ²⁾	K ₁	K ₂	K ₃	K ₄
15	47	23.5	15	16.0	72.6	53.6	38	30	26	24.55	6.70	24	19.90	16.30	16.20	15.20	16.80	3.20	3.20
20	63	31.5	20	21.5	91.0	65.6	53	40	35	32.50	7.30	30	25.35	20.75	20.55	19.80	19.80	3.35	3.35
25	70	35.0	23	23.5	107.9	79.5	57	45	40	38.30	11.50	36	29.90	24.45	24.25	23.30	24.45	5.50	5.50
30	90	45.0	28	31.0	119.7	89.4	72	52	44	48.40	14.60	42	35.35	28.55	28.35	25.00	26.70	6.05	6.05
35	100	50.0	34	33.0	139.0	105.5	82	62	52	58.00	17.35	48	40.40	32.15	31.85	28.75	30.25	6.90	6.90
45	120	60.0	45	37.5	174.1	133.5	100	80	60	69.80	20.90	60	50.30	40.15	39.85	35.50	37.50	8.20	8.20

Size	Dimensions (mm)										Mass (kg)	Load capacities ³⁾ (N)		Load moments ³⁾ (Nm)			
	N ₁	N ₂	N ₆ ^{±0.5}	S ₁	S ₂	S ₅	S ₉	T	V ₁	m		C	C ₀	M _t	M ₁₀	M _L	M _{L0}
15	5.2	4.40	10.3	4.3	M5	4.5	M2,5x3,5	60	5.0	0.30	12800	18400	120	180	120	180	
20	7.7	5.20	13.2	5.3	M6	6.0	M3x5	60	6.0	0.55	29600	41800	380	540	340	490	
25	9.3	7.00	15.2	6.7	M8	7.0	M3x5	60	7.5	0.90	37300	52500	530	750	530	740	
30	11.0	7.90	17.0	8.5	M10	9.0	M3x5	80	7.0	1.50	46000	66900	800	1160	740	1080	
35	12.0	10.15	20.5	8.5	M10	9.0	M3x5	80	8.0	2.25	66700	116000	1440	2500	1290	2240	
45	15.0	12.40	23.5	10.4	M12	14.0	M4x7	105	10.0	4.30	111000	190000	3010	5120	2730	4660	

- 1) Dimension H₂ with cover strip
- 2) Dimension H₂ without cover strip
- 3) Load capacities and load moments for ball runner block **without** ball chain. Load capacities and load moments for ball runner block **with** ball chain 12

Determination of the dynamic load capacities and load moments is based on a stroke travel of 100,000 m according to DIN ISO 14728-1. Often only 50,000 m are actually stipulated. For comparison: Multiply the values **C**, **M_t** and **M_L** by 1.26 according to the table.

FKS – Flange, short, standard height R1665 ... 2.

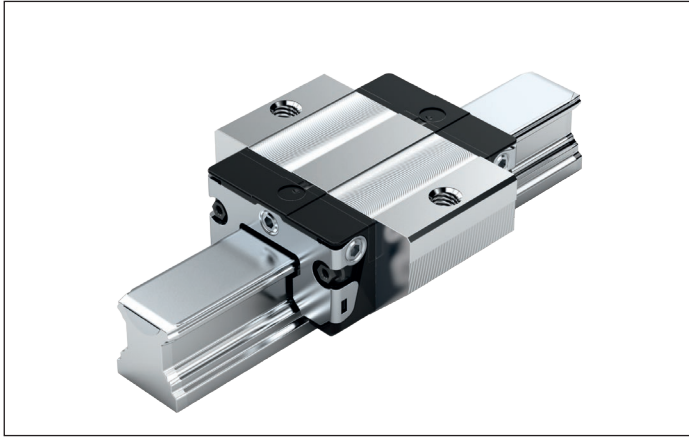

Dynamic characteristics

Speed: $v_{\max} = 5 \text{ m/s}$
 Acceleration: $a_{\max} = 500 \text{ m/s}^2$
 (If $F_{\text{comb}} > 2.8 \cdot F_{\text{pr}}$: $a_{\max} = 50 \text{ m/s}^2$)

Note on lubrication

► Pre-lubricated

Note

Can be used on all SNS/SNO ball guide rails.

Options and material numbers

Size	Ball runner block with size	Preload class		Accuracy class		Seal on ball runner block					
		C0	C1	N	H	without ball chain			with ball chain		
						SS	LS	DS	SS	LS	DS
15	R1665 1	9		4	3	20	21	–	22	23	–
			1	4	3	20	21	2Z	22	23	2Y
20	R1665 8	9		4	3	20	21	–	22	23	–
			1	4	3	20	21	2Z	22	23	2Y
25	R1665 2	9		4	3	20	21	–	22	23	–
			1	4	3	20	21	2Z	22	23	2Y
30	R1665 7	9		4	3	20	21	–	22	23	–
			1	4	3	20	21	2Z	22	23	2Y
35	R1665 3	9		4	3	20	21	–	22	23	–
			1	4	3	20	21	2Z	22	23	2Y
E.g.:	R1665 7		1		3	20					

Ordering example

Options:

- Ball runner block FKS
- Size 30
- Preload class C1
- Accuracy class H
- With standard seal, without ball chain

Material number:

R1665 713 20

Preload classes

C0 = Without preload (clearance)
 C1 = Moderate preload

Seals

SS = Standard seal
 LS = Low-friction seal
 DS = Double-lip seal

Key

gray numbers
 = no preferred variant / combination
 (partially longer delivery times)