

NSK Linear Guides™

High-Rigidity Series

RA/RB Model Roller Guides

Thanks to NSK's advanced analysis technologies, RA/RB roller guides realize super-high load capacity and rigidity. RA models with interchangeable rails and roller slides provide set preload and accuracy for custom combinations, while the RB model with low mounting height facilitates compact machine design.

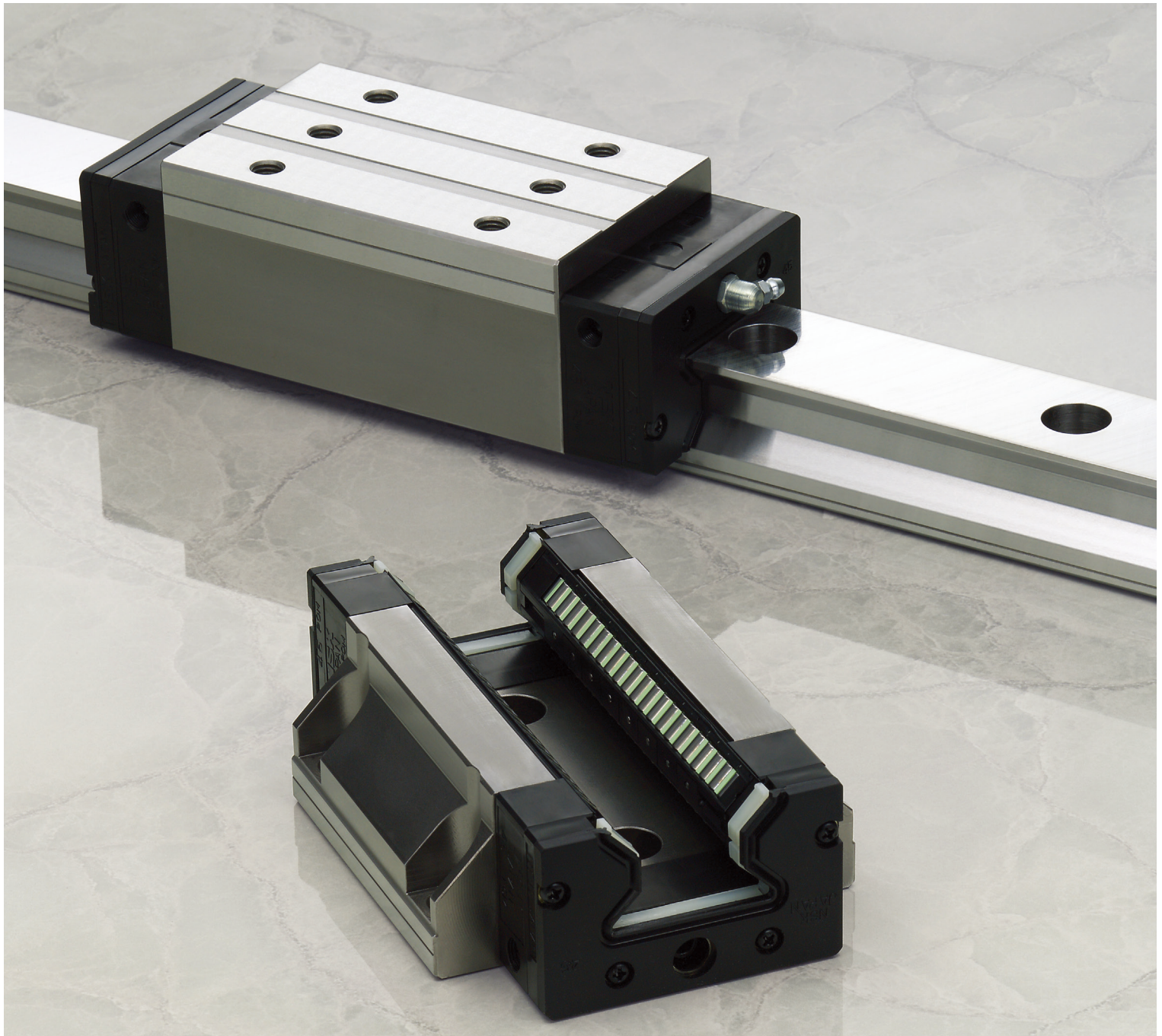

The fruits of NSK's comprehensive technologies: RA/RB roller guides suit a wide range of applications

RA/RB roller guides represent the culmination of NSK's extensive experience in roller bearings and linear guide technologies. Their optimized designs take full advantage of our unique expertise to realize smooth motion and super-high load capacity, rigidity, and motion accuracy. With their capacity to handle a variety of applications, RA/RB models help support higher machine performance to meet your needs.

Helping to achieve higher machine performance: Features of RA/RB roller guides

Super-Long Life

Super-high load capacity

RA/RB roller guides are among the best in the world—with unprecedented operating life thanks to their high load capacity.

Maintenance-free

Installing the NSK K1™ lubrication unit assures long-term, maintenance-free operation.

Highly dust resistant

Highly dust-resistant seals come equipped as standard to prevent the entry of foreign matter and ensure that performance does not worsen over time.

Help Advance High-Precision Manufacturing

Super-high rigidity

Super-high rigidity provides high-precision manufacturing.

Super-high motion accuracy

Coupled with NSK's unique design approach, the vibration caused by roller passage has been substantially reduced. This helps improve the quality of machined surfaces.

Smooth motion

The installation of a retaining piece achieves smooth motion, resulting in stable positioning accuracy.

Ideal Across Fields

Complete lineup

A wide lineup of sizes, including low-profile varieties, are available to match your application needs.

Standardized mounting dimensions

Outside dimensions and mounting dimensions conform to commonly used standards, allowing RA roller guides to be used without design changes (see Pages 17 and 18 for details).

Super low-profile RB model

With a low mounting height, the RB model supports compact machines and equipment downsizing.

Low friction

Using rollers for rolling elements suppresses dynamic friction.

Optimal Design

NSK conducts comprehensive and detailed performance simulations of roller guides by combining analysis and tribology technologies cultivated over many years of experience. These advancements have allowed us to attain thoroughly optimized designs down to the dimensions and shapes of the guide components.

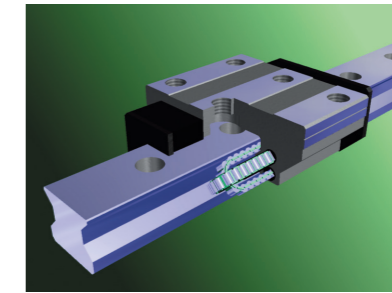

Smooth motion by use of retaining pieces

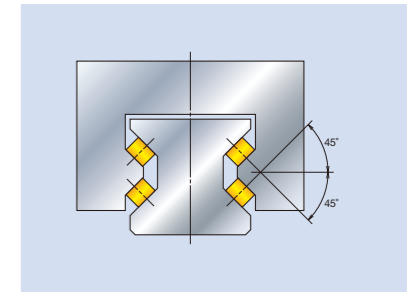

Balanced four-directional equal load specification

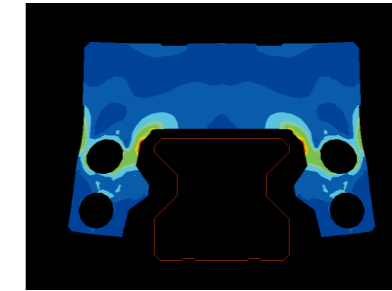

Example roller slide deformation analysis

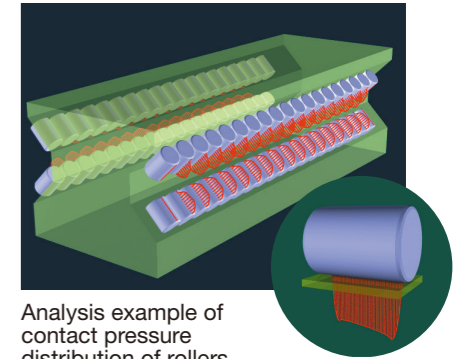

Analysis example of contact pressure distribution of rollers

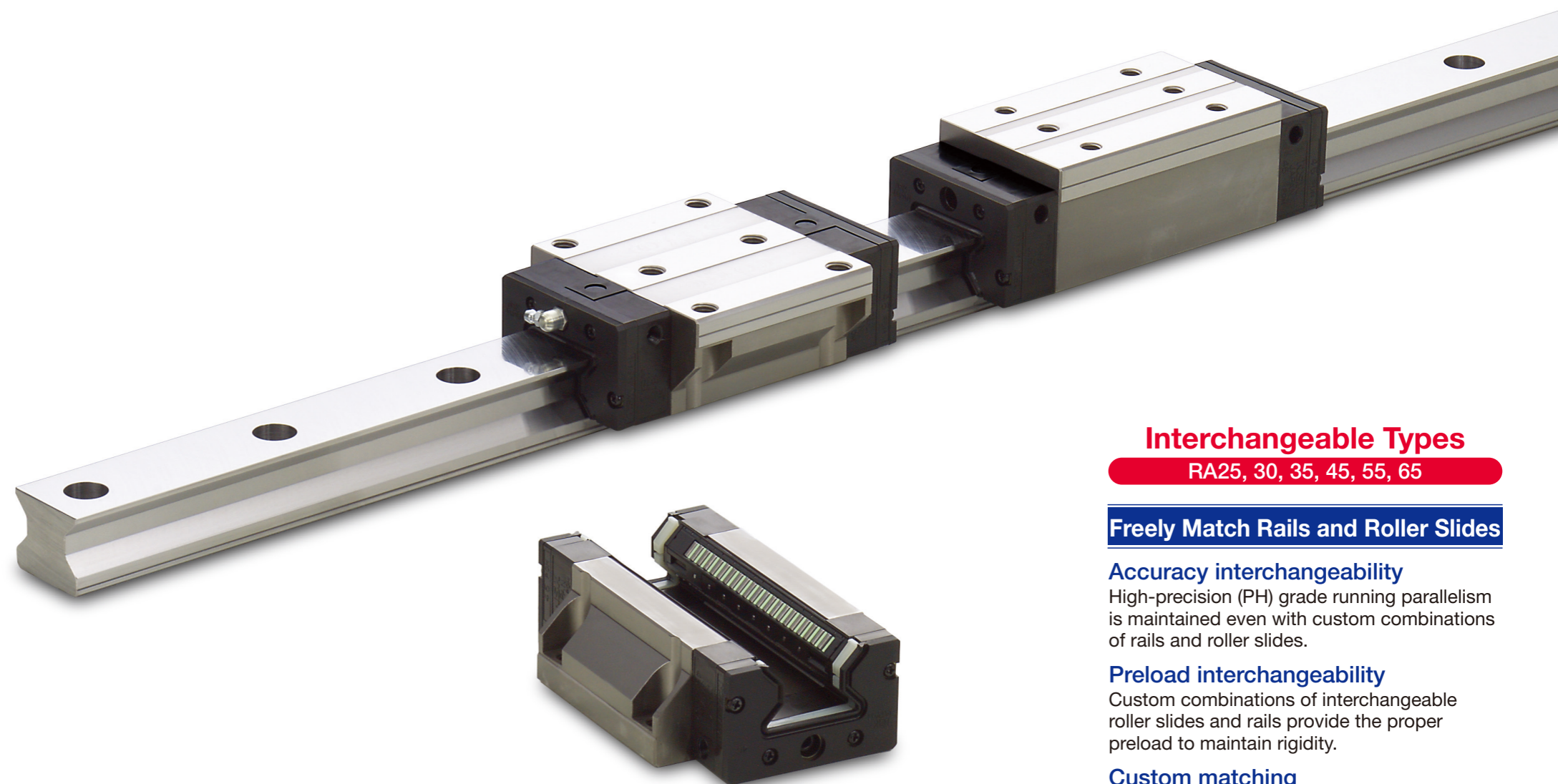

Interchangeable Types

RA25, 30, 35, 45, 55, 65

Freely Match Rails and Roller Slides

Accuracy interchangeability

High-precision (PH) grade running parallelism is maintained even with custom combinations of rails and roller slides.

Preload interchangeability

Custom combinations of interchangeable roller slides and rails provide the proper preload to maintain rigidity.

Custom matching

Rails and roller slides can be freely matched to suit the application.

Features

1. Super-high load capacity

Thanks to analysis technology, we installed rollers with the largest possible diameter and length within existing standard cross-section dimensions in a logical layout to realize super-high load capacity. This design achieves super-long life and is capable of handling impact loads.

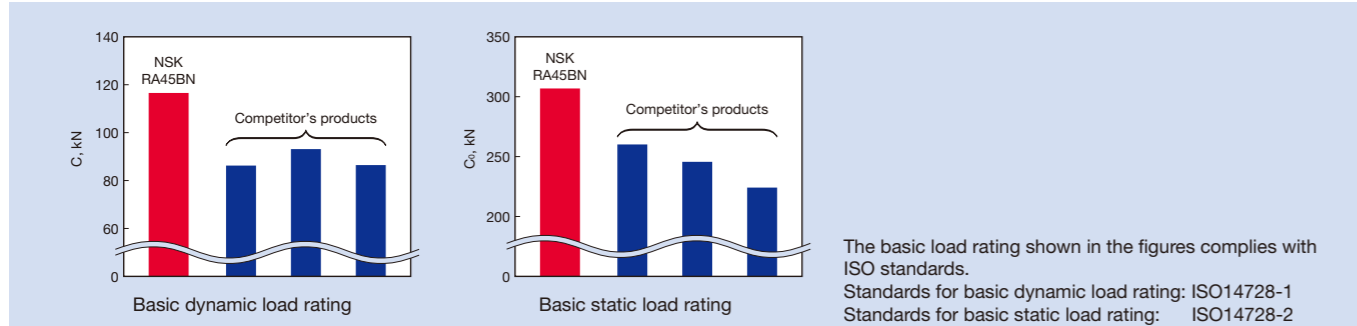

2. Super-high rigidity

Using NSK's advanced analysis technology, we pursued a complete, optimal design, down to the detailed shape of the roller slides and rails, thereby realizing super-high rigidity superior to that of competitors' roller guides.

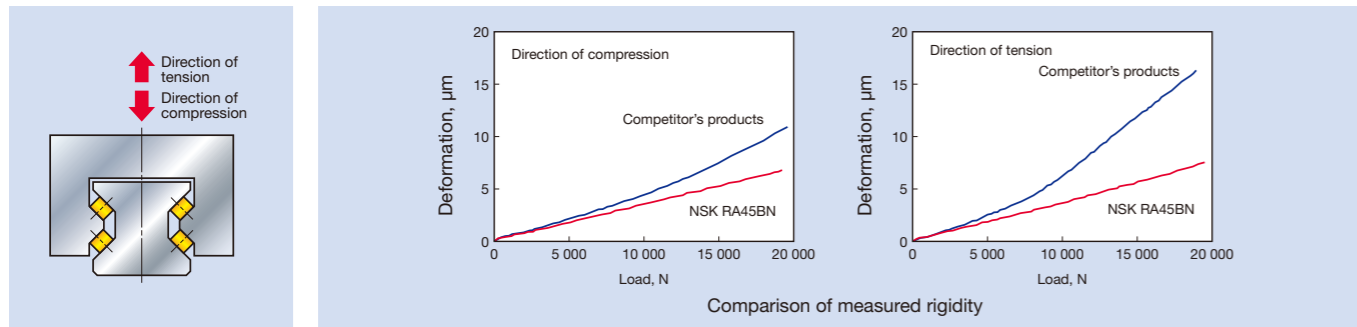

3. Super-high motion accuracy

NSK has developed its own unique method of simulating rolling element passage vibration and designing optimal roller slide specifications for damping. These developments have dramatically enhanced roller slide motion accuracy for the RA/RB models.

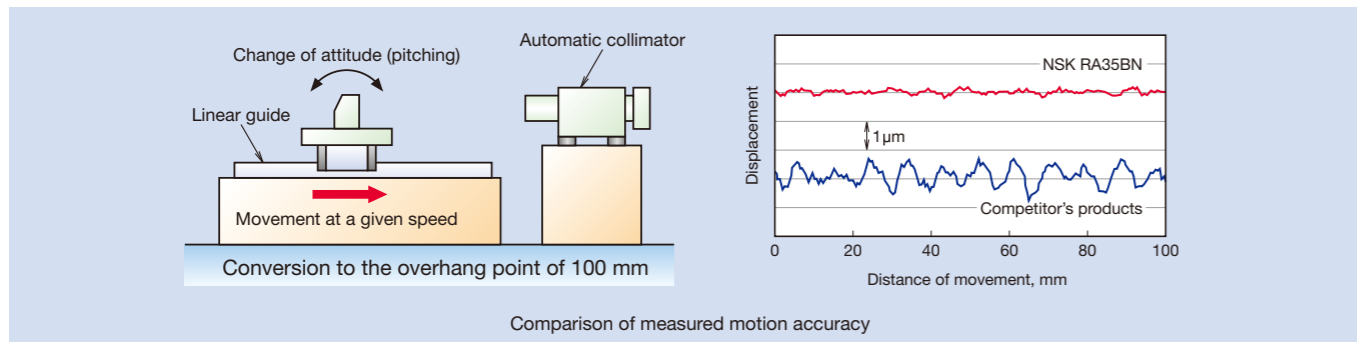

4. Standardized mounting dimensions

Outside dimensions and mounting dimensions conform to international standards, allowing RA roller guides to be used without design changes (see Pages 17 and 18 for details).

5. Smooth motion

Installing a retaining piece between rollers and restraining the skew peculiar to roller bearings achieve smooth motion. The reduction of friction variation provides stable tracking in the complicated trajectory control.

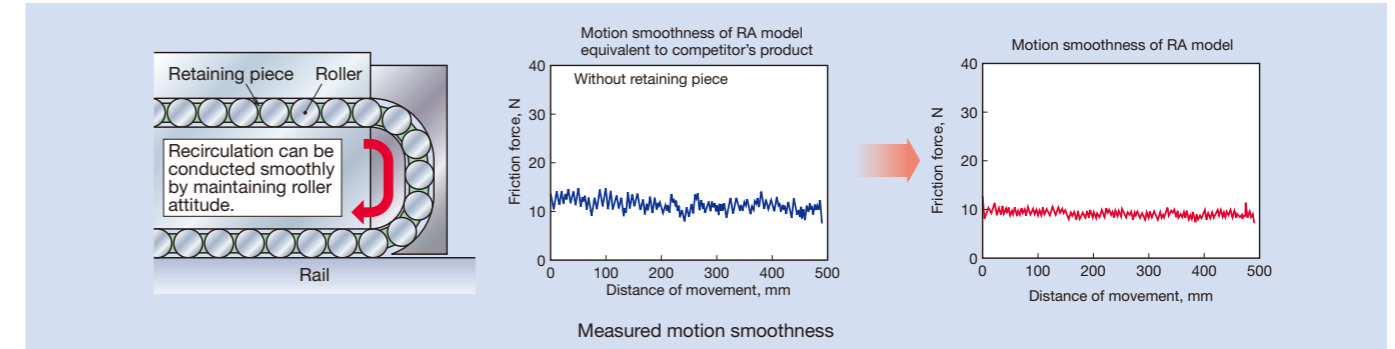

6. Low friction

Using rollers for rolling elements helps minimize dynamic friction.

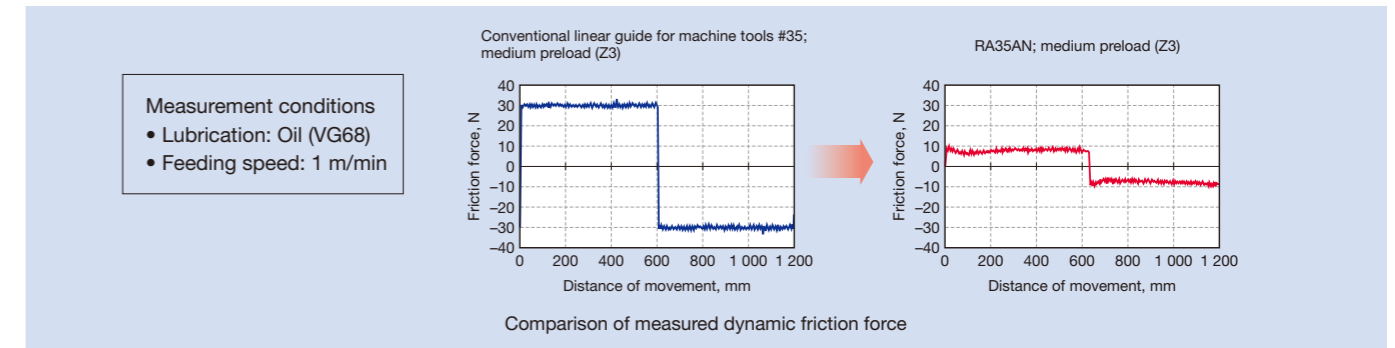

7. Low noise

A retaining piece is provided between rollers to prevent collisions and minimize noise.

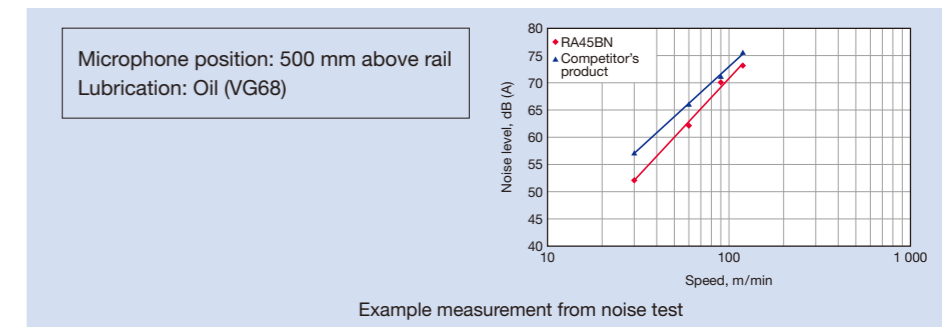

8. Highly dust-resistant, maintenance-free operation

Various roller slides, bolt-hole caps, and rail covers are available as options.

The field-proven NSK K1™ lubrication unit is also available for long-term, maintenance-free operation. (Availability of options depends on size. For details on dust-resistant specifications, please see page 13.)

Specifications

1. Roller Slide Types and Shapes

- Roller slides are available in square, flanged, and low-profile types. Compact RB models come in low-profile and flanged types, offering even lower height than RA models.
- The mounting holes of the flanged type have a tapped part used to fix the roller slide from the top surface and a tapped minor diameter section for use as bolt holes from the bottom. This allows for mounting from either the top or bottom.
- Roller slide length can be specified as the high load/standard type or the super-high load/long type.

RA model

Fig. 1 Square type

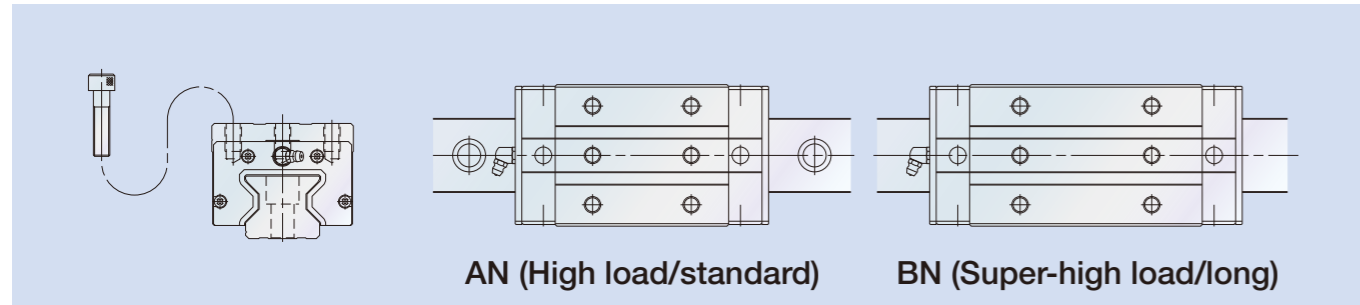

Fig. 2 Low-profile type

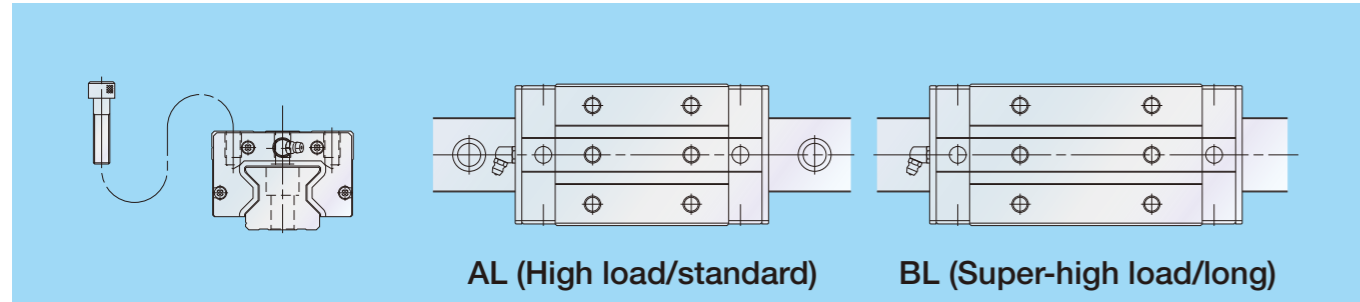
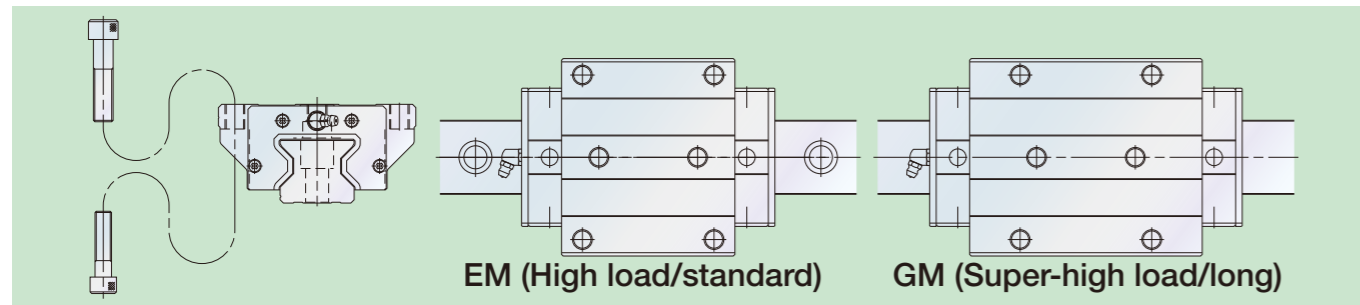

Fig. 3 Flanged type



RB model

Fig. 4 Low-profile type

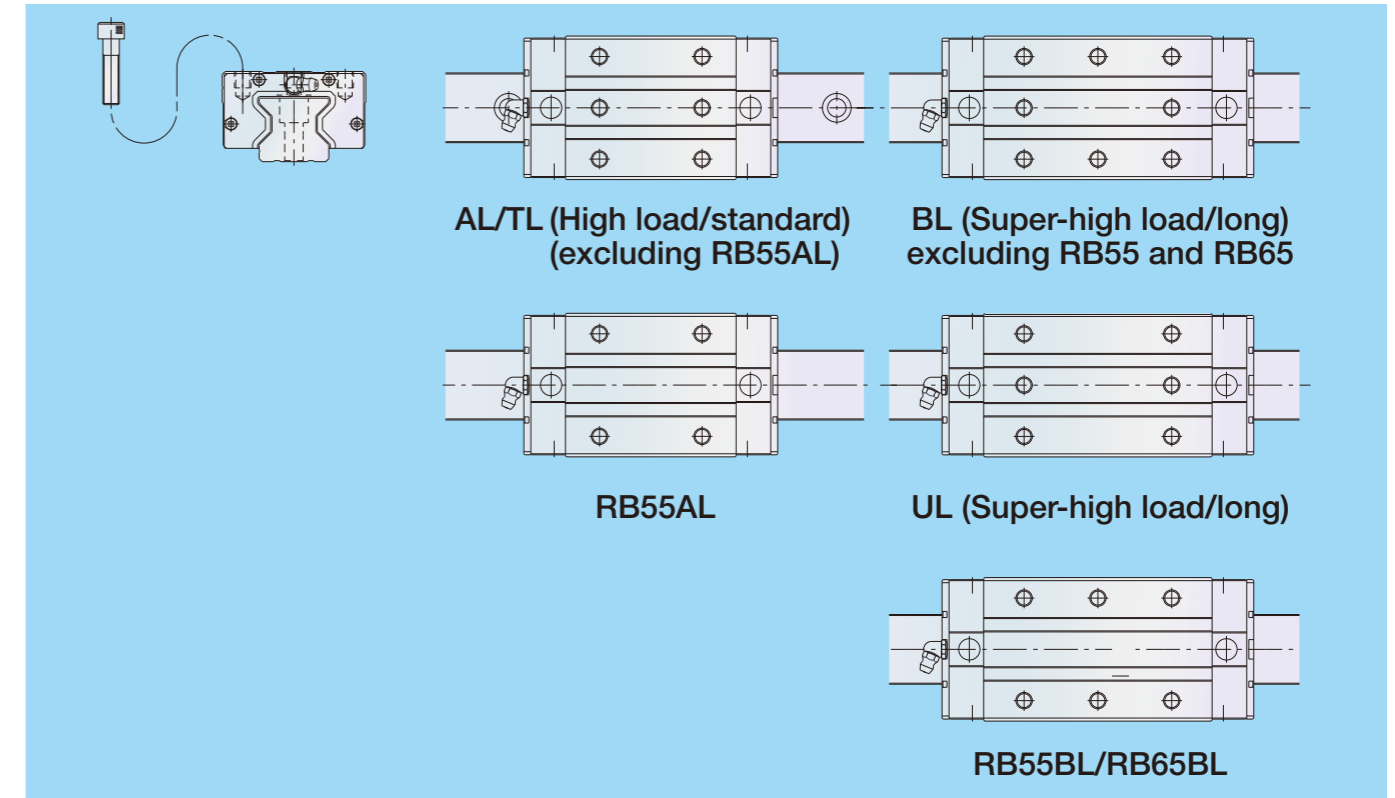
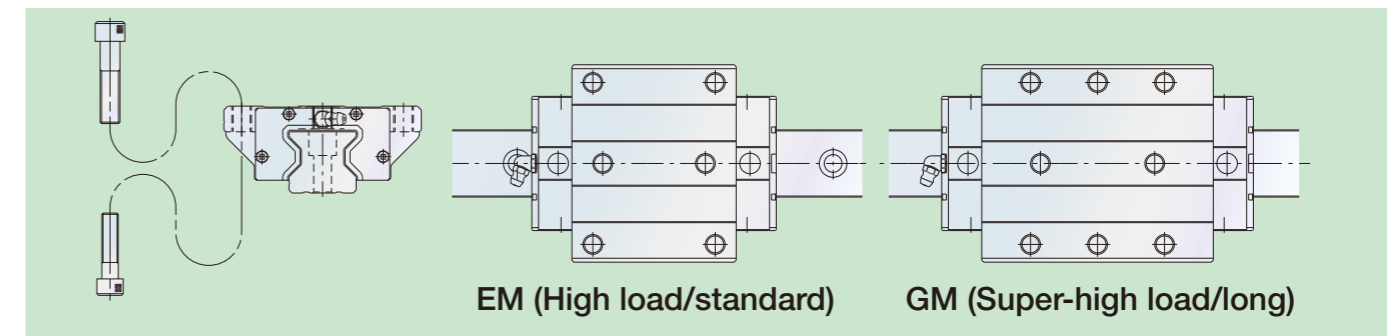

Fig. 5 Flanged type



2. Accuracy

Four accuracy grades are available for preloaded assemblies: Ultra precision P3, Super precision P4, High precision P5, and Precision P6. RA model interchangeable types offer High precision PH grade only.

Table 1 Tolerance of preloaded assembly

Characteristics	Accuracy grade			
	Ultra precision P3	Super precision P4	High precision P5	Precision grade P6
Mounting height H	± 8	± 10	± 20	± 40
Variation of H (All roller slides on a set of rails)	3	5	7	15
Mounting width W_2 or W_3	± 10	± 15	± 25	± 50
Variation of W_2 or W_3 (All roller slides on reference rail)	3	7	10	20
Running parallelism of surface C to surface A Running parallelism of surface D to surface B	See Table 3 and Fig. 6			

Unit: μm

Table 2 Tolerance of interchangeable type Unit: μm

Characteristics	Accuracy grade	High precision PH
Mounting height H		± 20
Variation of mounting height H		15 ①
		25 ②
Mounting width W_2 or W_3		± 25
Variation of mounting width W_2 or W_3		20
Running parallelism of surface C to surface A		See Table 3 and Fig. 6
Running parallelism of surface D to surface B		

Note: ① Variation on the same rail ② Variation on multiple rails

Table 3 Running parallelism Unit: μm

Rail length (mm)	Ultra precision P3	Super precision P4	High precision P5, PH	Precision grade P6
over - 50 or less	2	2	2	4
50 - 80	2	2	3	4
80 - 125	2	2	3	4
125 - 200	2	2	3.5	5
200 - 250	2	2.5	4.5	6
250 - 315	2	2.5	5	6.5
315 - 400	2	3	5.5	7
400 - 500	2	3	6	7.5
500 - 630	2	3.5	6.5	8.5
630 - 800	2	4	7	9.5
800 - 1 000	2.5	4.5	7.5	10
1 000 - 1 250	3	5	8.5	12
1 250 - 1 600	3.5	5.5	9.5	13
1 600 - 2 000	4	6.5	11	14
2 000 - 2 500	4.5	7.5	12	16
2 500 - 3 150	5.5	8.5	13	18
3 150 - 4 000	6	9.5	14	19

Fig. 6 Accuracy specifications

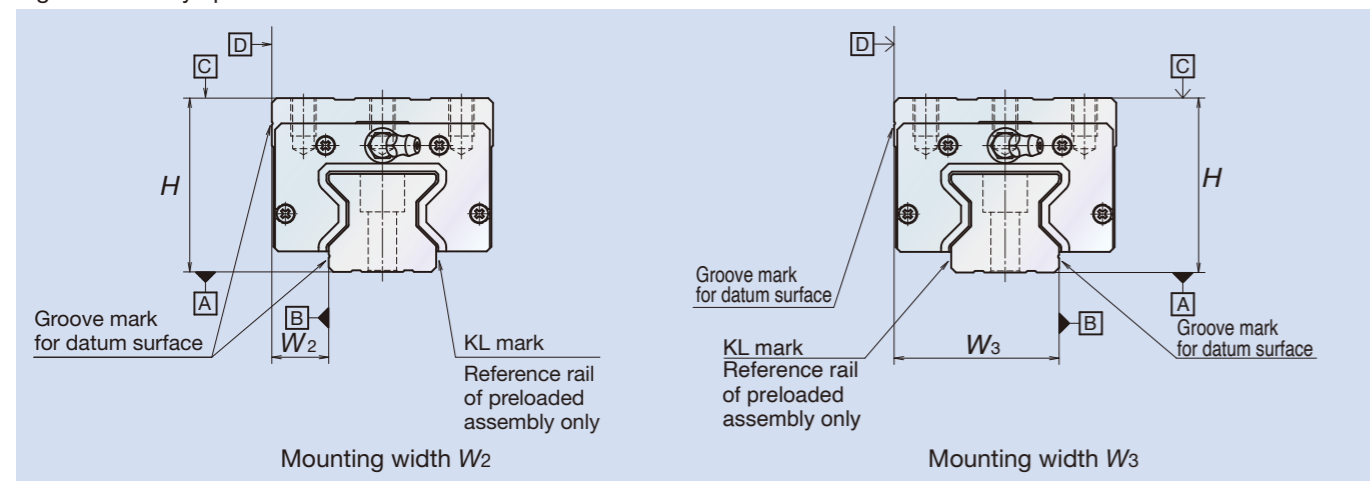

3. Preload and Rigidity

Medium preload Z3 is available for preloaded assemblies, with slight preload Z1 also available for the RA model only. Medium preload ZH and slight preload ZZ are available for the interchangeable RA model. Typical data for preload and rigidity are shown below.

Table 4 RA model: Preload Unit: N

Model No.	High-load		Super-high-load	
	Slight preload (Z1)	Medium preload (Z3)	Slight preload (Z1)	Medium preload (Z3)
RA15	520	1 030	650	1 300
RA20	960	1 920	1 200	2 400
RA25	880	2 920	1 060	3 540
RA30	1 170	3 890	1 430	4 760
RA35	1 600	5 330	2 020	6 740
RA45	2 780	9 280	3 500	11 600
RA55	3 800	12 900	5 000	16 800
RA65	6 500	21 000	8 500	28 800

Table 5 RB model: Preload Unit: N

Model No.	High-load	Super-high-load
	Medium preload (Z3)	Medium preload (Z3)
RB30	3 890	4 760
RB35	5 330	6 740
RB45	9 280	11 600
RB55	12 900	16 800
RB65	21 000	28 800

Fig. 7 RA model: Theoretical vertical direction rigidity

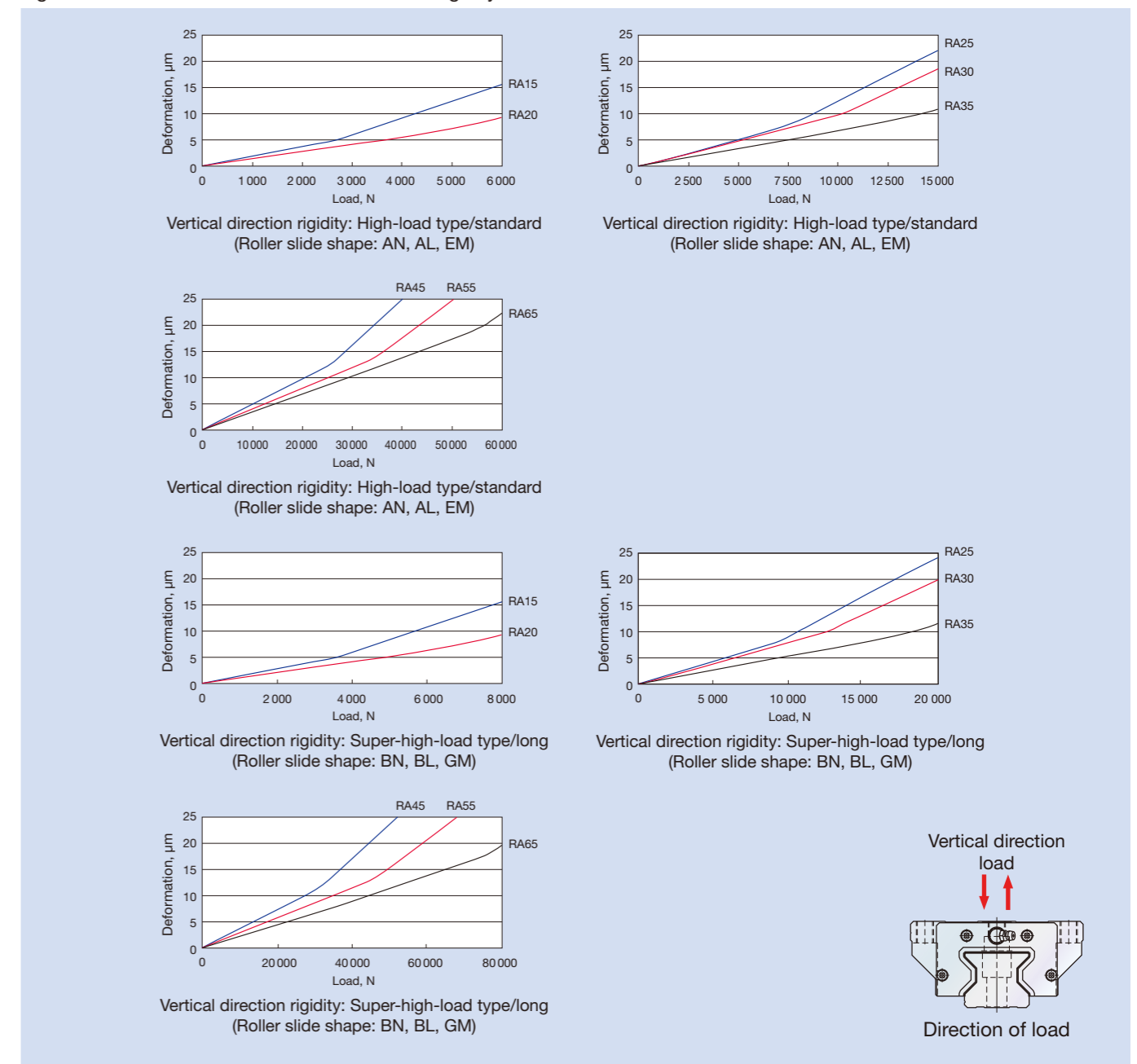
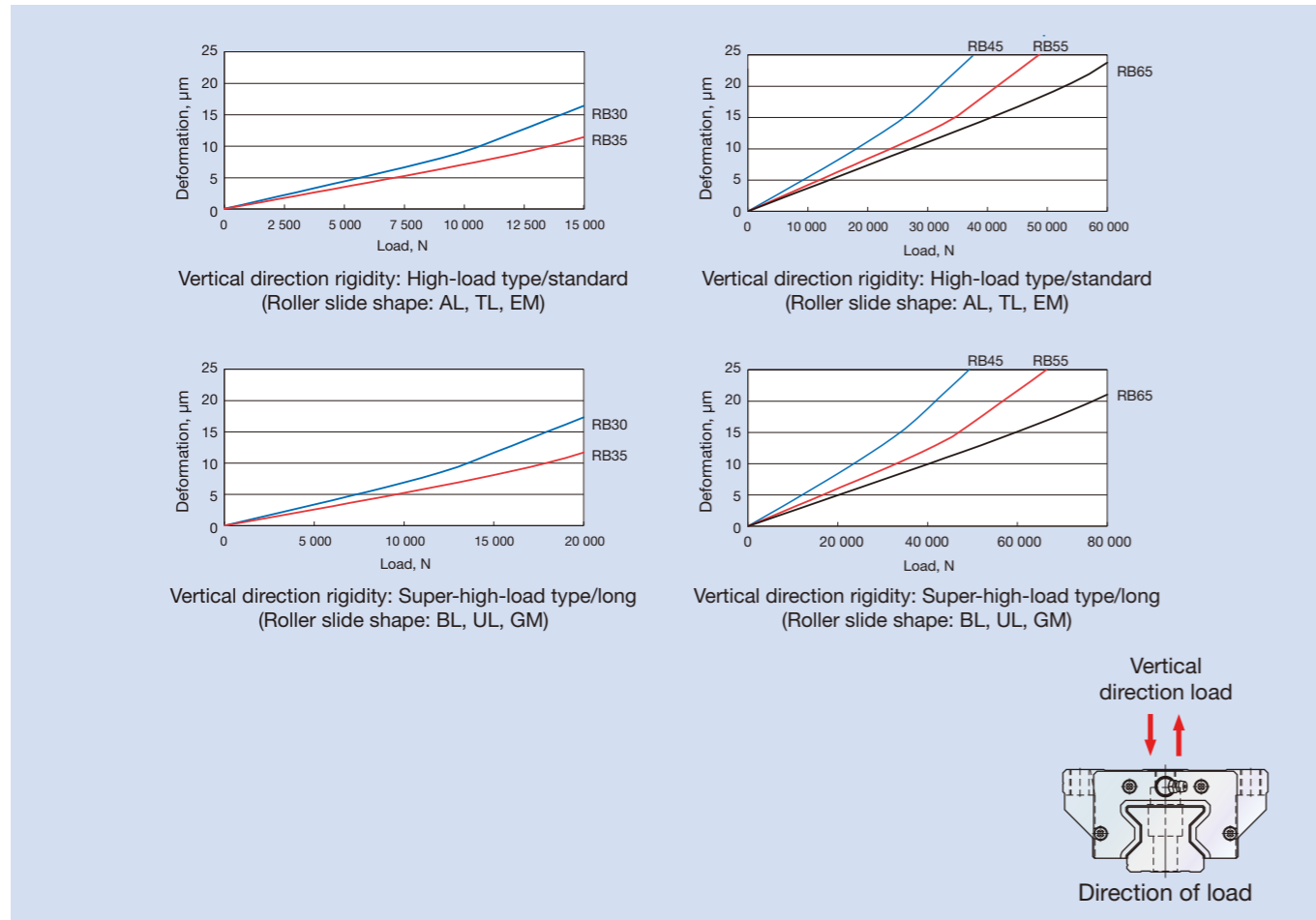

Fig. 8 RB model: Theoretical vertical direction rigidity



4. Basic Load Rating and Rated Life

The basic dynamic load rating used to express the load capacity of a linear guide is determined by ISO standards (ISO 14728-1). The load is specified to not change in amount or direction so that the rating fatigue life is 100 km. The basic load ratings of NSK Linear Guides are based on ISO standards. RA/RB models feature 4-way equal load specifications, making their dynamic load ratings the same in both vertical and lateral directions.

The slide's rated fatigue life L can be calculated using the following equation where load F is applied to the roller slide in only one vertical or horizontal direction.

- This life formula is different from that for linear guides with balls as the rolling elements.
- f_w refers to a load factor. Select the appropriate load factor shown in Table 6 based on vibration and impacts on the machine where the linear guide will be used.

$$L = 100 \times \left(\frac{C}{f_w \cdot F} \right)^{\frac{10}{3}} \text{ (km)}$$

Various loads may be applied to the linear guide (i.e., roller slide loads), including vertical loads, lateral loads, and moment loads. Sometimes, more than one type of load will be applied simultaneously or the amount and direction of the load may vary.

Variable loads cannot be used for life calculations of linear guides as they are. Therefore, it is necessary to use an applied hypothetical constant load that would generate a fatigue life equivalent to the actual fatigue life. This is called the dynamic equivalent load. To calculate dynamic equivalent load, use the values provided in Table 7.

Fig. 9 Direction of load

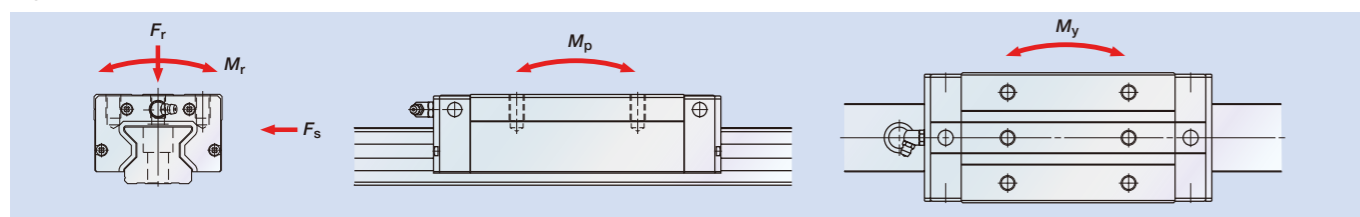

Table 7 Loads by arrangement of linear guide

Pattern	Arrangement of linear guide	Loads necessary to calculate dynamic equivalent load					Dynamic equivalent load
		Load		Moment load			
		Up/down (vertical)	Right/left (lateral)	Rolling	Pitching	Yawing	
1		F_r	F_s	M_r	M_p	M_y	$F_r = F_r$ $F_{se} = F_s \cdot \tan \alpha$
2		F_r	F_s	M_r			$F_{re} = \epsilon_r \cdot M_r$ $F_{pe} = \epsilon_p \cdot M_p$ $F_{ye} = \epsilon_y \cdot M_y$
3		F_r	F_s		M_p	M_y	α : Contact angle ($\approx 45^\circ$) Dynamic equivalent coefficient
4		F_r	F_s				ϵ_r : Rolling direction ϵ_p : Pitching direction ϵ_y : Yawing direction

After obtaining the dynamic equivalent coefficient in Table 8 or 9, the full dynamic equivalent load can be obtained using the appropriate equation below as determined by the magnitude of the load:

- When F_r is the largest load: $F_e = F_r + 0.5F_{se} + 0.5F_{re} + 0.5F_{pe} + 0.5F_{ye}$
- When F_{se} is the largest load: $F_e = 0.5F_r + F_{se} + 0.5F_{re} + 0.5F_{pe} + 0.5F_{ye}$
- When F_{re} is the largest load: $F_e = 0.5F_r + 0.5F_{se} + F_{re} + 0.5F_{pe} + 0.5F_{ye}$
- When F_{pe} is the largest load: $F_e = 0.5F_r + 0.5F_{se} + 0.5F_{re} + F_{pe} + 0.5F_{ye}$
- When F_{ye} is the largest load: $F_e = 0.5F_r + 0.5F_{se} + 0.5F_{re} + 0.5F_{pe} + F_{ye}$

The values for dynamic equivalent load in the formulas above should be absolute values that disregard load directions.

Table 8 RA model: Dynamic equivalent coefficient

Model No.	Dynamic equivalent coefficient (1/m)		
	ϵ_r	ϵ_p	ϵ_y
RA15 High load type	105	95	95
RA15 Super-high load type	105	70	70
RA20 High load type	79	74	74
RA20 Super-high load type	79	55	55
RA25 High load type	71	64	64
RA25 Super-high load type	71	50	50
RA30 High load type	56	58	58
RA30 Super-high load type	56	44	44
RA35 High load type	46	52	52
RA35 Super-high load type	46	39	39
RA45 High load type	37	40	40
RA45 Super-high load type	37	30	30
RA55 High load type	32	33	33
RA55 Super-high load type	32	24	24
RA65 High load type	26	28	28
RA65 Super-high load type	26	19	19

Table 9 RB model: Dynamic equivalent coefficient

Model No.	Dynamic equivalent coefficient (1/m)		
	ϵ_r	ϵ_p	ϵ_y
RB30 High load type	56	58	58
RB30 Super-high load type	56	44	44
RB35 High load type	46	52	52
RB35 Super-high load type	46	39	39
RB45 High load type	37	40	40
RB45 Super-high load type	37	30	30
RB55 High load type	32	33	33
RB55 Super-high load type	32	24	24
RB65 High load type	26	28	28
RB65 Super-high load type	26	19	19

5. Lubrication Specifications

(1) Types of lubrication accessories

- Fig. 12 and Tables 11.1 and 11.2 show details on grease fittings and tube fittings.

(2) Mounting positions for lubrication accessories

- The standard position for grease fittings and tube fittings is on the end face of the roller slide. We can mount them on the side of the end cap as an option (Fig. 10). Please consult NSK to install grease or tube fittings to the roller slide body or to the side of an end cap.
- A lubrication hole can also be provided on top of the end cap. In this case, an O ring will be necessary. Fig. 11 and Tables 10.1-10.3 show mounting positions. Some AN/BN slides require spacers, which are available from NSK.
- When using a piping unit with a thread of M6 × 1, a connector is required to connect the piping unit to a grease fitting mounting hole with M6 × 0.75. Connectors are available from NSK.

(3) Oil lubrication precautions

- When oil lubrication is used, the oil may not reach the rolling surface under some roller slide mounting conditions (upside down, wall mountings, etc.) Please consult with NSK before use in these situations.
- When using an oil mist lubricating system, please confirm that a sufficient amount of oil reaches each outlet port.

Fig. 10 Mounting positions for lubrication accessories

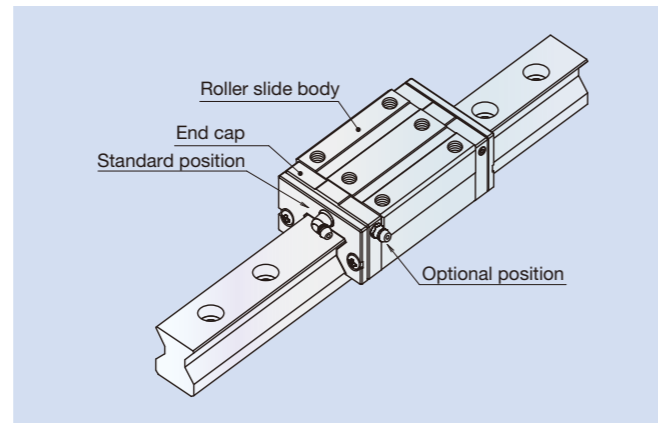

Fig. 11 Top and side lubrication hole positions

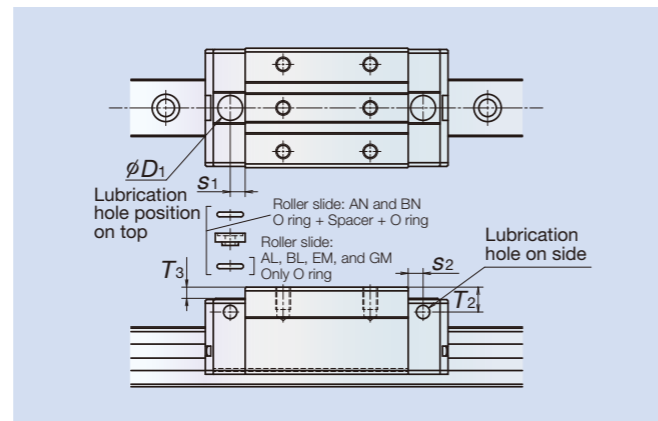

Table 10.1 RA model: Top and side lubrication hole positions

Unit: mm

Model No.	Roller slide shape code	Grease fitting size	s_2	T_2	O ring (JIS)	Spacer	D_1	s_1	T_3
RA15	AN, BN	$\phi 3$	4	7	P5	Necessary	8.2	4.4	4.2
RA20		$\phi 3$	4	4	P6	-	9.2	5.4	0.2
RA25		M6x0.75	6	10	P7	Necessary	10	6	4.5
RA30		M6x0.75	5	10	P7+P5	Necessary	10.4	6	3.5
RA35		M6x0.75	5.5	15	P7+P5	Necessary	10.4	7	7.4
RA45		Rc 1/8	7.2	20	P7+P5	Necessary	10.4	7.2	10.4
RA55		Rc 1/8	7.2	21	P7+P5	Necessary	10.4	7.2	10.4
RA65		Rc 1/8	7.2	19	P7	-	10.4	7.2	0.4

Note: Grease fittings and tube fittings cannot be mounted on the top of the end cap.

Table 10.2 RA model: Top and side lubrication hole positions

Unit: mm

Model No.	Roller slide shape code	Grease fitting size	s_2	T_2	O ring (JIS)	D_1	s_1	T_3
RA15	AL, BL, EM, GM	$\phi 3$	4	3	P5	8.2	4.4	0.2
RA20	EM, GM	$\phi 3$	4	4	P6	9.2	5.4	0.2
RA25	AL, BL, EM, GM	M6x0.75	6	6	P7	10	6	0.5
RA30		M6x0.75	5	7	P7	10.4	6	0.5
RA35		M6x0.75	5.5	8	P7	10.4	7	0.4
RA45		Rc 1/8	7.2	10	P7	10.4	7.2	0.4
RA55		Rc 1/8	7.2	11	P7	10.4	7.2	0.4
RA65	EM, GM	Rc 1/8	7.2	19	P7	10.4	7.2	0.4

Note: Grease fittings and tube fittings cannot be mounted on the top of the end cap.

Table 10.3 RB model: Top and side lubrication hole positions

Unit: mm

Model No.	Grease fitting size	s_2	T_2	O ring (JIS)	D_1	s_1	T_3
RB30	M6x0.75	5	6.5	P7	10.4	6	0.5
RB35	M6x0.75	5.5	6.5	P7	10.4	7	0.4
RB45	M6x0.75	7.2	6.5	P7	10.4	7.2	0.4
RB55	M6x0.75	7.2	8	P7	10.4	7.2	0.4
RB65	M6x0.75	7.2	10	P7	10.4	7.2	0.4

Note: Grease fittings and tube fittings cannot be mounted on the top of the end cap.

Table 11.1 RA model: Lubrication accessory thread length

Unit: mm

Model No.	Dust-resistant specification	Dimension L		
		Grease fitting / Drive-in type	Tube fitting	
			SF type	LF type
RA15	Standard	5	-	-
	With NSK K1	10	-	-
	Double seal	8	-	-
	Protector	8	-	-
RA20	Standard	5	-	-
	With NSK K1	10	-	-
	Double seal	8	-	-
	Protector	10	-	-
RA25	Standard	5	5	5
	With NSK K1	12	12	12
	Double seal	10	9	9
	Protector	10	9	9
RA30	Standard	5	6	6
	With NSK K1	14	14	15
	Double seal	12	12	11
	Protector	12	10	11
RA35	Standard	5	6	6
	With NSK K1	14	14	15
	Double seal	12	12	11
	Protector	12	10	11
RA45	Standard	8	13.5	17
	With NSK K1	18	20	21.5
	Double seal	14	16	17
	Protector	14	16	17
RA55	Standard	8	13.5	17
	With NSK K1	18	20	21.5
	Double seal	14	16	17
	Protector	14	16	17
RA65	Standard	8	13.5	17
	With NSK K1	20	20	20
	Double seal	14	18	17
	Protector	14	16	17

Table 11.2 RB model: Lubrication accessory thread length

Unit: mm

Model No.	Dust-resistant specification	Dimension L		
		Grease fitting / Drive-in type	Tube fitting	
			SF type	LF type
RB30	Standard	5	-	-
	With NSK K1	10	-	-
	Double seal	8	-	-
	Protector	8	-	-
RB35	Standard	5	5	5
	With NSK K1	14	15	16
	Double seal	12	12	12
	Protector	12	12	12
RB45	Standard	5	5	5
	With NSK K1	14	15	16
	Double seal	12	12	12
	Protector	12	12	12
RB55	Standard	8	13.5	17
	With NSK K1	18	20	21.5
	Double seal	14	16	17
	Protector	14	16	17
RB65	Standard	8	13.5	17
	With NSK K1	20	20	20
	Double seal	14	18	17
	Protector	14	16	17

Fig. 12 Grease fittings and tube fittings

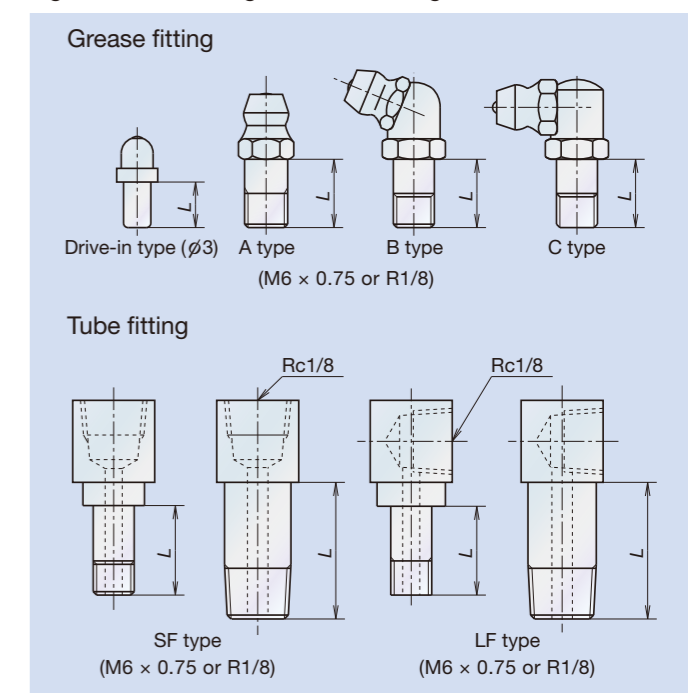

6. Dust-resistant specifications

(1) Standard specification

RA and RB models are equipped with end, inner¹⁾ and bottom seals to prevent foreign matter from entering the inside of the roller slide. Under normal applications, RA and RB models can be used without modification. For severe usage conditions, optional rail covers are available. Contact NSK for information on how to mount the cover.

Fig. 13 View of roller slide equipped with dust-resistant parts

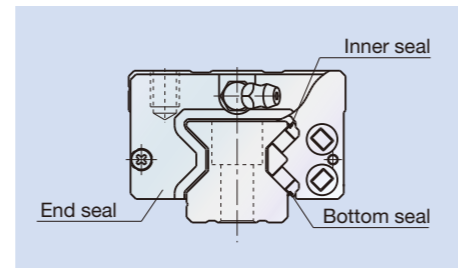

Fig. 14 Rail cover



Table 12 Optional parts for dust resistance

Name	Purpose
NSK K1 lubrication unit	Made of oil impregnated resin. Enhances lubricating functions.
Double seal	Combines two end seals for enhanced seal effectiveness.
Protector	Protects the end seal from hot and hard contaminants.
Rail cap	Prevents foreign matter, such as swarf generated in cutting, from clogging the rail-mounting holes.
Rail cover ²⁾	Covers the rail top surface, and prevents foreign matter, such as cutting dust, from collecting in the rail mounting holes.

1) Inner seals for models RA15 and RA20 are available as an option. 2) Rail covers are available for models RA25 to RA65.

(2) NSK K1™ lubrication unit

Tables 13 and 14 show the dimensions of linear guides equipped with the NSK K1 lubrication unit.

Table 13 RA Model: Slide lengths with NSK K1

Model No.	Roller slide length	Roller slide shape code	Standard roller slide length	Roller slide length with two NSK K1 installed L	Thickness of single NSK K1 V ₁	Protrusion of grease fitting N
RA15	Standard	AN, AL, EM	70	79	4.5	(3)
	Long	BN, BL, GM	85.4	94.4		
RA20	Standard	AN, EM	86.5	95.5	4.5	(3)
	Long	BN, GM	106.3	115.3		
RA25	Standard	AN, AL, EM	97.5	107.5	5	(11)
	Long	BN, BL, GM	115.5	125.5		
RA30	Standard	AN, AL, EM	110.8	122.8	6	(11)
	Long	BN, BL, GM	135.4	147.4		
RA35	Standard	AN, AL, EM	123.8	136.8	6.5	(11)
	Long	BN, BL, GM	152	165		
RA45	Standard	AN, AL, EM	154	168	7	(14)
	Long	BN, BL, GM	190	204		
RA55	Standard	AN, AL, EM	184	198	7	(14)
	Long	BN, BL, GM	234	248		
RA65	Standard	AN, EM	228.4	243.4	7.5	(14)
	Long	BN, GM	302.5	317.5		

Note: Roller slide length when equipped with NSK K1 = (standard roller slide length) + (V₁ thickness of single NSK K1 unit) × (number of K1 units).

Fig. 15 Slide with NSK K1

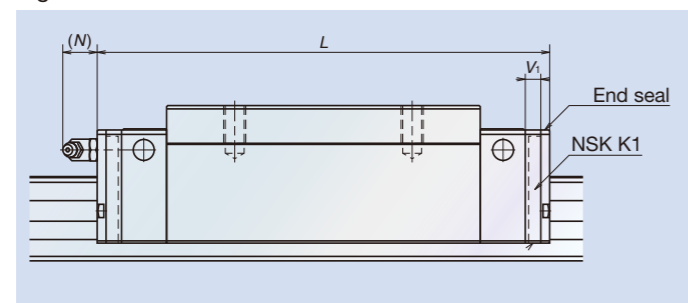

Table 14 RB Model: Slide lengths with NSK K1

Model No.	Roller slide length	Roller slide shape code	Standard roller slide length	Roller slide length with two NSK K1 installed L	Thickness of single NSK K1 V ₁	Protrusion of grease fitting N
RB30	Standard	AL, EM	110.8	122.8	6	(3)
	Long	BL, GM	135.4	147.4		
RB35	Standard	AL, EM	123.8	136.8	6.5	(11)
	Long	BL, GM	152	165		
RB45	Standard	AL, EM	154	168	7	(11)
	Long	BL, GM	190	204		
RB55	Standard	AL, TL, EM	184	198	7	(14)
	Long	BL, UL, GM	234	248		
RB65	Standard	AL, EM	228.4	243.4	7.5	(14)
	Long	BL, UL, GM	302.5	317.5		

Note: Roller slide length when equipped with NSK K1 = (standard roller slide length) + (V₁ thickness of single NSK K1 unit) × (number of K1 units).

(3) Double seal and protector

Double seals and protectors for RA/RB models can only be installed before shipping from the factory. Tables 15 and 16 show the increased thickness of end seals and protectors.

Fig. 16 Slide with end seal/protector

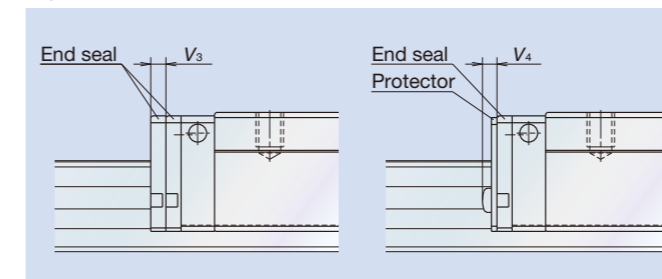

Table 15 Increased thickness of RA model options Unit: mm

Model No.	Thickness of end seal V ₃	Thickness of protector V ₄
RA15	3	2.7
RA20	3	3.3
RA25	3.2	3.3
RA30	3.4	3.6
RA35	3.4	3.6
RA45	4	4.2
RA55	4	4.2
RA65	5	5.5

Table 16 Increased thickness of RB model options Unit: mm

Model No.	Thickness of end seal V ₃	Thickness of protector V ₄
RB30	3.4	3.6
RB35	3.4	3.6
RB45	4	4.2
RB55	4	4.2
RB65	5	5.5

(4) Rail cover

Use a cover bracket to fix the rail cover when installing. Fig. 17 shows cover bracket dimensions. The protrusion from the end of the rail will be:

Inside: 10.5 mm or less

Outside: 4 mm or less (models RA25 to RA65)

Please confirm the stroke and space at the rail end in your machine.

Table 17 shows rail height when a rail cover is installed.

Fig. 17 End configuration of rail equipped with rail cover

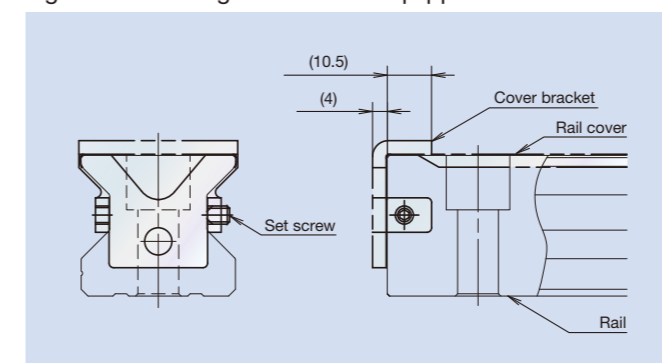

Table 17 Height of rails equipped with rail cover Unit: mm

Model No.	Standard rail height H ₁	Rail height installed with rail cover
RA25	24	24.2
RA30	28	28.2
RA35	31	31.25
RA45	38	38.3
RA55	43.5	43.8
RA65	55	55.3

(5) Caps to plug rail mounting bolt holes

Bolt sizes for rail mounting and cap reference numbers are shown in Tables 18 and 19.

Table 18 RA model: Caps for rail mounting holes

Model No.	Bolt to secure rail	Cap reference No.	Quantity/case
RA15	M4	LG-CAP/M4	20
RA20	M5	LG-CAP/M5	
RA25	M6	LG-CAP/M6	
RA30, RA35	M8	LG-CAP/M8	
RA45	M12	LG-CAP/M12	
RA55	M14	LG-CAP/M14	
RA65	M16	LG-CAP/M16	

Table 19 RB model: Caps for rail mounting holes

Model No.	Bolt to secure rail	Cap reference No.	Quantity/case
RB30, RB35	M8	LG-CAP/M8	20
RB45	M12	LG-CAP/M12	
RB55	M14	LG-CAP/M14	
RB65	M16	LG-CAP/M16	

(6) Bellows

Bellows are available for the RA model.

Installation of bellows

Fixing to the roller slide

Remove the two machine screws that secure the end seal. (For RA15, hold the end cap by hand or the end cap may detach from the slide and the rollers may fall out.)

Place a spacer ring on the mounting hole of the end seal and fasten the mounting plate at the end of the bellows using a slightly longer machine screw. (For RA15, place a spacer plate between the end seal and the mounting plate at the end of the bellows.)

Fixing to the rail

First, make tap holes on the rail end surface. Fix the bellows mounting plate to the rail end surface with machine screws through these tap holes. NSK processes tap holes on the rail end surface when a linear guide and bellows are ordered as a set.

Calculating bellows length

The formulas for calculating the length of end bellows are as follows.

Stroke

$$S_t = L_{max} - L_{min}$$

Length when stretched to the maximum

$$L_{max} = f_b \cdot P \times \text{Number of folds}$$

Length when contracted to the minimum

$$L_{min} = 2.5 \times \text{Number of folds} + 3$$

Values for f_b and P are shown in the bellows dimension table. Based on the above formulas, you may calculate the number of folds as follows:

$$\text{Number of folds} = \frac{S_t - 3}{f_b \cdot P - 2.5}$$

Round up the calculated value so that the number of folds will be $n + 0.5$ (n : a natural number). Please contact NSK regarding the length of middle bellows.

If considering bellows for the RB model, please consult with NSK.

Bellows reference number

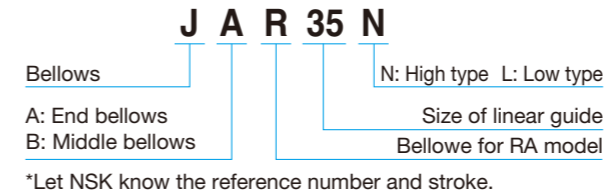

Fig. 18 Bellows dimensions

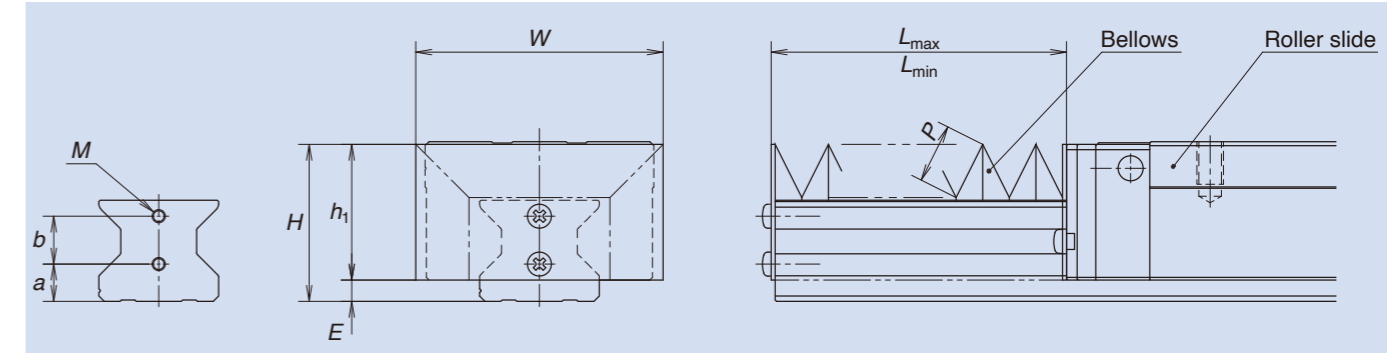

Table 20 Bellows dimensions

Unit: mm (excluding f_b)

Model No.	H	h ₁	E	W	P	f _b	a	b	Tap M × depth
JAR15L	23.5	19.5	4	33	7	1.2	7	6.3	M3x5
JAR15N	27	23		39	10	1.3			
JAR20N	29	24	5	43	8	1.3	8.5	9	M3x5
JAR25L	35	30	5	55	10	1.3			
JAR25N	39	34		61	14	1.4			
JAR30L	41	34.5	6.5	60	12	1.3	11	12.5	M4x6
JAR30N	44	37.5		66	15	1.4			
JAR35L	47	40.5	6.5	72	15	1.4	11	15	M4x6
JAR35N	54	47.5		82	20	1.5			
JAR45L	59	51	8	93	20	1.5	14	18	M5x8
JAR45N	69	61		113	30	1.5			
JAR55L	69	60	9	101	20	1.5	15	22	M5x8
JAR55N	79	70		121	30	1.5			
JAR65N	89	76	13	131	30	1.5	21	26	M6x10

Note: f_b is a dimensionless number.

7. Maximum rail length

Tables 21 and 22 show rail length limits (maximum lengths) for a single rail in the RA/RB models; however, note that limits vary by accuracy grade.

Table 21 RA model: Rail length limits

Unit: mm

Size	RA15	RA20	RA25	RA30	RA35	RA45	RA55	RA65
Maximum length	2 000	3 000	3 900	3 900	3 900	3 650	3 600	3 600

Table 22 RB model: Rail length limits

Unit: mm

Size	RB30	RB35	RB45	RB55	RB65
Maximum length	3 900	3 900	3 650	3 600	3 600

Note: Rails can be butted if user requirements exceed the rail length shown in the table. Please consult NSK for details.

8. Installation

(1) Permissible mounting error

Improper mounting results in harmful effects such as shortened operating life, deterioration of motion accuracy, and friction variation.

NSK places a strong focus on operating life—we set permissible mounting error to values where the operating life will be calculated to exceed 10 000 km assuming the following conditions:

- The load per roller slide is 10% of basic dynamic load rating C.
- The rigidity of machine is infinite.

Permissible mounting error is shown in Table 23 using the representative error shown in Fig. 19.

Fig. 19 Permissible mounting error

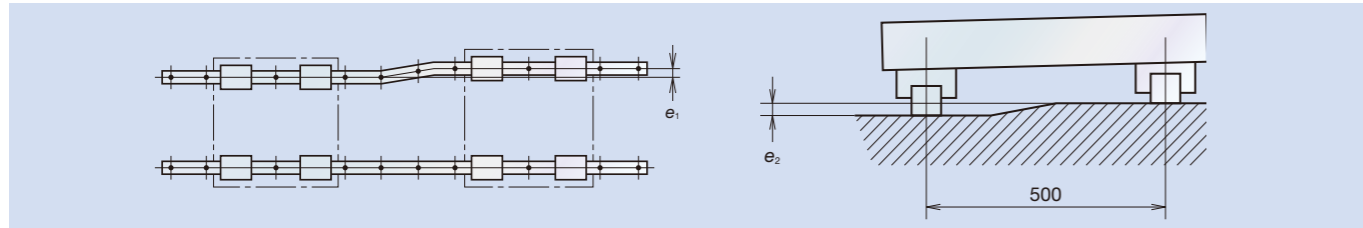

Table 23 RA model: Permissible mounting error

Unit: μm

Value	Preload	Model No.							
		RA15	RA20	RA25	RA30	RA35	RA45	RA55	RA65
Permissible values for parallelism error of two rails e_1	Z1, ZZ	7	10	14	18	21	27	31	49
	Z3, ZH	5	7	9	11	13	17	19	30
Permissible values for height error of two rails e_2	Z1, ZZ	290μm/500mm							
	Z3, ZH	150μm/500mm							

Table 24 RB model: Permissible mounting error

Unit: μm

Value	Preload	Model No.				
		RB30	RB35	RB45	RB55	RB65
Permissible values for parallelism error of two rails e_1	Z3	11	13	17	19	30
Permissible values for height error of two rails e_2	Z3	150μm/500mm				

(2) Shoulder height and corner radius of mounting surface

Fig. 20 and Tables 25 and 26 show shoulder height and corner radius of the mounting surface when the rail or slide is pressed against the shoulder of the machine base or table (the raised section of the mounting surface) and fixed horizontally.

Fig. 20 Datum faces of roller guide and shoulder

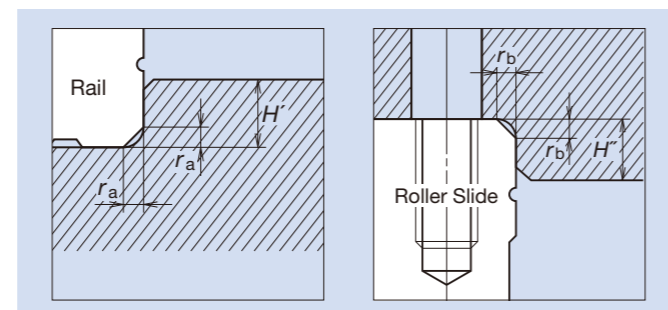

Table 25 RA model: Shoulder height and corner radius of the mounting surface

Unit: mm

Model No.	Shoulder height		Corner radius (maximum)	
	H'	H''	r_a	r_b
RA15	3	4	0.5	0.5
RA20	4	5	0.5	0.5
RA25	4	5	0.5	1
RA30	5	6	1	1
RA35	5	6	1	1
RA45	6	8	1.5	1
RA55	7	10	1.5	1.5
RA65	11	11	1.5	1.5

Table 26 RB model: Shoulder height and corner radius of the mounting surface

Unit: mm

Model No.	Shoulder height		Corner radius (maximum)	
	H'	H''	r_a	r_b
RB30	5	6	1	1
RB35	5	6	1	1
RB45	6	8	1.5	1
RB55	7	10	1.5	1.5
RB65	8	11	1.5	1.5

Handling Precautions

- ① Operating temperature limits should normally be less than 80°C.
- ② If using NSK K1™, service temperature should not exceed 50°C (or 80°C momentarily). Make sure the unit does not come in contact with organic solvents that can be used for degreasing. Do not place the unit in a location exposed to white kerosene or rust prevention oil containing white kerosene.
- ③ To transfer a slide onto/from a rail, please note the following:
 - Do not remove the roller slide from the rail unless absolutely necessary.
 - When moving the roller slide onto or off of a rail, use the provided provisional rail to prevent dents and scratches on the raceways from excessive force and to prevent the rollers from falling out.
 - Ensure that the bottom and side of the provisional rail are aligned to the rail that the slide will be transferred onto/from and move the slide while butting the end faces of the rails.
 - Use a clean provisional rail. Do not use with a rail that is contaminated with foreign matter or that uses a different type of lubricant.

Square type (tapped mounting holes)

RA-AN (High load/standard), RA-BN (Super-high load/long)

(1) Reference number for preloaded assembly

RA 35 1000 AN C 2 - P6 3**

Model name	RA 35 1000 AN C 2 -** P6 3	Preload code	P6
Size	35	1: Z1, 3: Z3, Z: ZZ, H: ZH	
Rail length (mm)	1000	Accuracy code	**
Roller slide shape code: AN, BN	AN	(Without NSK K1): P3, P4, P5, P6, PH (With NSK K1): K3, K4, K5, K6, KH	
Material/surface treatment code	C	Design serial number	
C: Special high carbon steel (NSK standard)		Added to the reference number.	
		Number of roller slides per rail	3

(2) Reference number for interchangeable type

RAA 35 AN PH H -F

Roller slide	RAA 35 AN PH H -F	Option code	-F
Interchangeable roller slide model code	RAA 35 AN PH H -F	No code: No surface treatment	
Roller slide shape code: AN, BN	AN	-F: Fluoride low temperature chrome plating	
		-C: No surface treatment + Rail cover	
		-CF: Fluoride low temperature chrome plating + Rail cover	
		Preload code	H
		Z: Slight preload, H: Medium preload	
		Accuracy code	PH
		PH, KH: High-precision grade interchangeable type	

R1A 35 1000 L C N - PH Z**

Rail	R1A 35 1000 L C N -** PH Z	Preload code	Z
Interchangeable rail model code	R1A 35 1000 L C N -** PH Z	Z: Common for slight and medium preload	
Roller slide shape code: AN, BN	AN	Accuracy code	PH
		PH: High-precision grade interchangeable type	
		Design serial number	
		Added to the reference number.	
		*Butting rail specification	
		N: Non-butting, L: Butting specification	
		*Please consult with NSK for butting rail specifications.	

Assembly

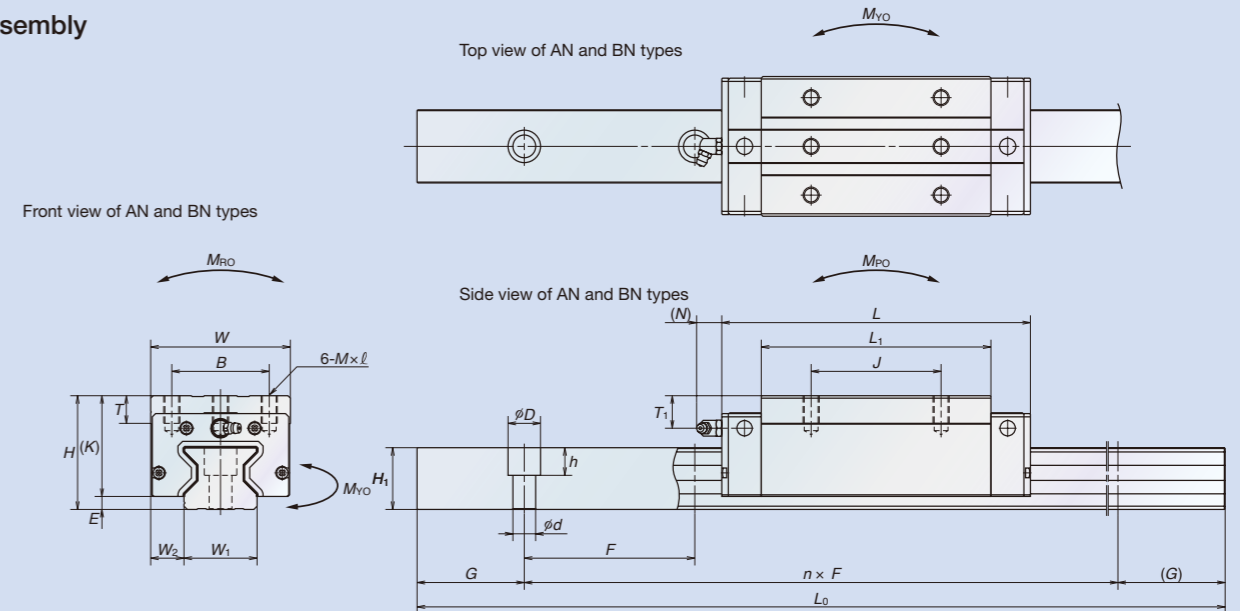

Interchangeable roller slide

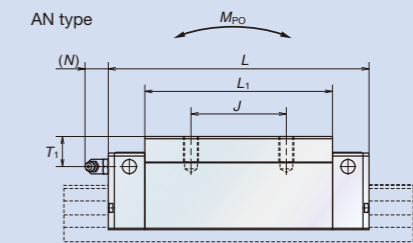

Interchangeable rail

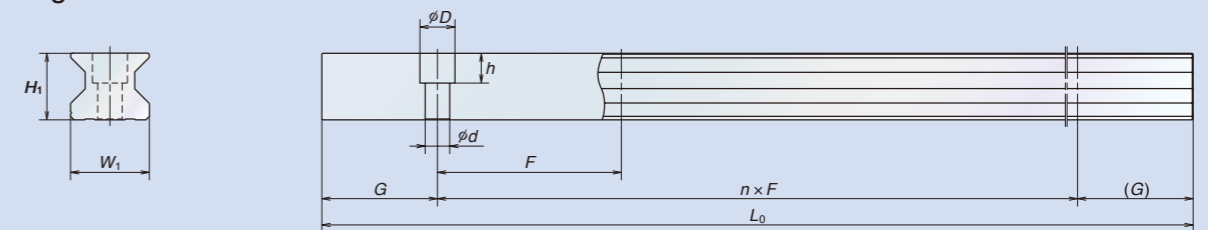

Unit: mm

Model No.	Assembly			Roller slide									Rail					Basic load ratings								Weight				
	Height H	E	W ₂	Width W	Length L	Mounting hole			L ₁	K	T	Grease fitting			Width W ₁	Height H ₁	Pitch F	Mounting bolt hole d x D x h	G (reference)	Maximum length L _{0max}	Dynamic		Static C ₀ (N)	Static moment (N·m)				Roller slide (kg)	Rail (kg/m)	
						Hole size	T ₁	N				[50km] C ₅₀ (N)	[100km] C ₁₀₀ (N)	M _{P0}							M _{Y0}									
RA15AN RA15BN	28	4	9.5	34	70 85.4	26	26	M4x0.7x6	44.8 60.2	24	8	phi 3	8	3	15	16.3	60 (30)	4.5x7.5x5.3	20	2 000	12 600 16 000	10 300 13 000	27 500 37 000	260 350	210 375	1 320 2 130	210 375	1 320 2 130	0.21 0.30	1.6
RA20AN RA20BN	30	5	12	44	86.5 106.3	32	36 50	M5x0.8x6	57.5 77.3	25	12	phi 3	4	3	20	20.8	60 (30)	6x9.5x8.5	20	3 000	23 600 29 500	19 200 24 000	52 500 70 000	665 890	505 900	3 100 5 000	505 900	3 100 5 000	0.38 0.50	2.6
RA25AN RA25BN	40	5	12.5	48	97.5 115.5	35	35 50	M6x1x9	65.5 83.5	35	12	M6x0.75	10	11	23	24	30 (60)	7x11x9	20	3 900	36 000 43 500	29 200 35 400	72 700 92 900	970 1 240	760 1 240	4 850 7 200	760 1 240	4 850 7 200	0.60 0.91	3.4
RA30AN RA30BN	45	6.5	16	60	110.8 135.4	40	40 60	M8x1.25x11	74 98.6	38.5	14	M6x0.75	10	11	28	28	40 (80)	9x14x12	20	3 900	47 800 58 500	38 900 47 600	93 500 121 000	1 670 2 170	1 140 1 950	7 100 11 500	1 140 1 950	7 100 11 500	1.0 1.3	4.9
RA35AN RA35BN	55	6.5	18	70	123.8 152	50	50 72	M8x1.25x12	83.2 111.4	48.5	15	M6x0.75	15	11	34	31	40 (80)	9x14x12	20	3 900	65 500 82 900	53 300 67 400	129 000 175 000	2 810 3 810	1 800 3 250	11 000 17 800	1 800 3 250	11 000 17 800	1.6 2.1	6.8
RA45AN RA45BN	70	8	20.5	86	154 190	60	60 80	M10x1.5x17	105.4 141.4	62	17	R _C 1/8	20	14	45	38	52.5 (105)	14x20x17	22.5	3 650	114 000 143 000	92 800 116 000	229 000 305 000	6 180 8 240	4 080 7 150	24 000 39 000	4 080 7 150	24 000 39 000	3.0 4.1	10.9
RA55AN RA55BN	80	9	23.5	100	184 234	75	75 95	M12x1.75x18	128 178	71	18	R _C 1/8	21	14	53	43.5	60 (120)	16x23x20	30	3 600	159 000 207 000	129 000 168 000	330 000 462 000	10 200 14 300	7 060 13 600	41 000 72 000	7 060 13 600	41 000 72 000	4.9 6.7	14.6
RA65AN RA65BN	90	13	31.5	126	228.4 302.5	76	70 120	M16x2x20	155.4 229.5	77	22	R _C 1/8	19	14	63	55	75 (150)	18x26x22	35	3 600	259 000 355 000	210 000 288 000	504 000 756 000	19 200 28 700	12 700 28 600	78 500 153 000	12 700 28 600	78 500 153 000	9.3 12.2	22.0

Notes: 1) Select either the standard dimension for pitch F as shown without parentheses, or the semi-standard dimension as shown inside parentheses. If not specified, the standard dimension for F will be applied.

2) The interchangeable type is available for models RA25 to RA65.
3) Basic load ratings comply with ISO standards (ISO 14728-1, 14728-2).

C₅₀: Basic dynamic load rating for 50 km rated fatigue life
C₁₀₀: Basic dynamic load rating for 100 km rated fatigue life

Low profile type (tapped mounting holes)

RA-AL (High load/standard), RA-BL (Super-high load/long)

(1) Reference number for preloaded assembly
RA 35 1000 AL C 2 - P6 3**

Model name: RA 35 1000 AL C 2 -** P6 3
 Size: 35
 Rail length (mm): 1000
 Roller slide shape code: AL, BL
 Material/surface treatment code: C: Special high carbon steel (NSK standard)

Preload code: 3
 Accuracy code: P6
 Design serial number: **
 Number of roller slides per rail: 2

(2) Reference number for interchangeable type
R1A 35 1000 L C N - PH Z**

Roller slide: RAA 35 AL PH H -F
 Interchangeable roller slide model code: RAA 35 AL PH H -F
 Size: 35
 Roller slide shape code: AL, BL

Rail: R1A 35 1000 L C N -** PH Z
 Interchangeable rail model code: R1A 35 1000 L C N -** PH Z
 Size: 35
 Rail length (mm): 1000
 Rail shape code: L
 Material/surface treatment code: Z

Option code: -F: Fluoride low temperature chrome plating, -C: No surface treatment + Rail cover, -CF: Fluoride low temperature chrome plating + Rail cover
 Preload code: Z: Slight preload, H: Medium preload
 Accuracy code: PH, KH: High-precision grade interchangeable type
 Preload code: Z: Common for slight and medium preload
 Accuracy code: PH: High-precision grade interchangeable type
 Design serial number: **
 *Butting rail specification: N: Non-butting, L: Butting specification
 *Please consult with NSK for butting rail specifications.

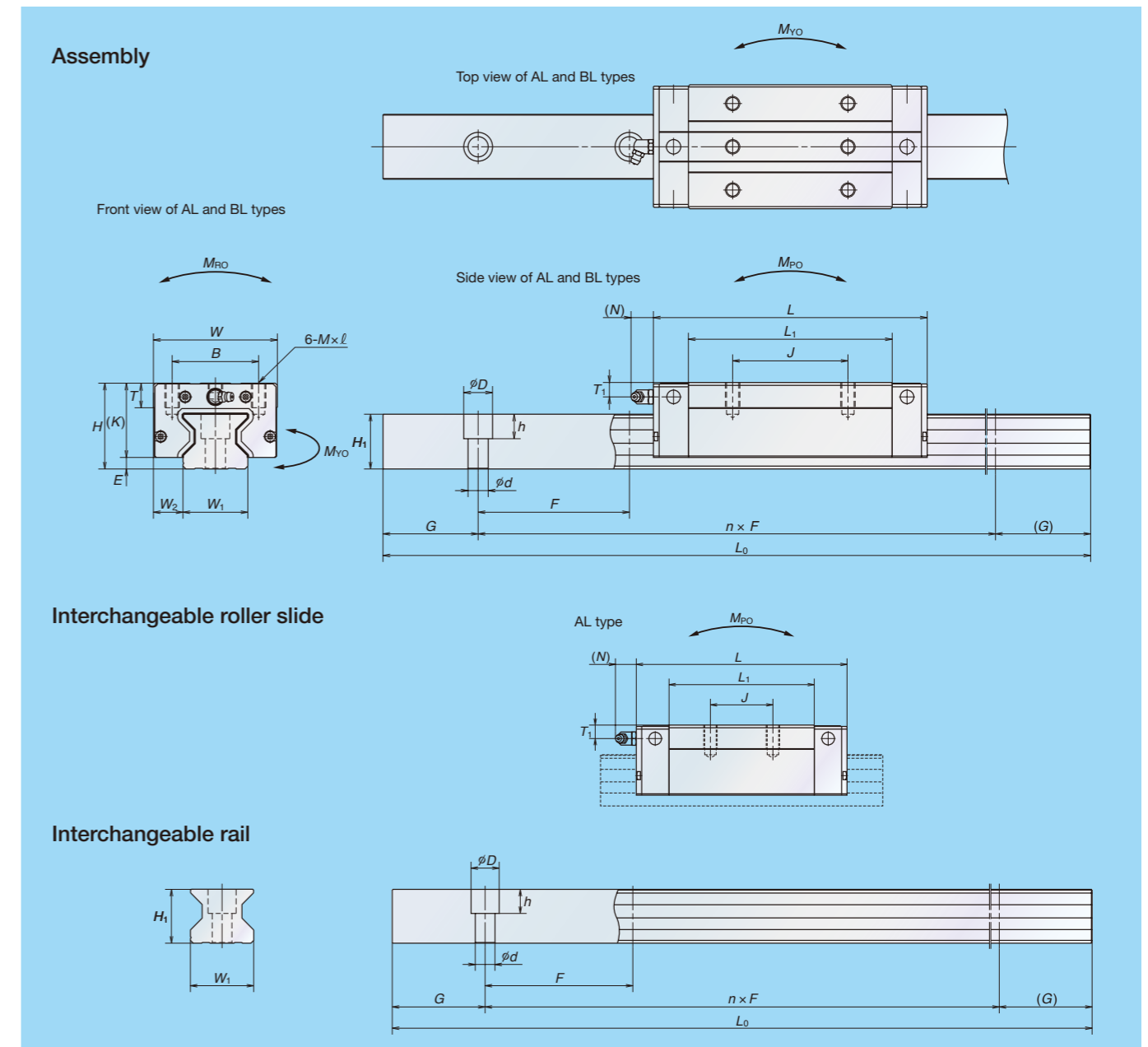

Model No.	Assembly			Roller slide									Rail					Basic load ratings								Weight				
	Height H	E	W ₂	Width W	Length L	Mounting hole			L ₁	K	T	Grease fitting			Width W ₁	Height H ₁	Pitch F	Mounting bolt hole d×D×h	G (reference)	Maximum length L _{0max}	Dynamic		Static C ₀ (N)	Static moment (N·m)				Roller slide (kg)	Rail (kg/m)	
						[50km] C ₅₀ (N)	[100km] C ₁₀₀ (N)	M _{P0}				M _{Y0}																		
RA15AL RA15BL	24	4	9.5	34	70 85.4	26	26	M4×0.7×5.5	44.8 60.2	20	8	φ3	4	3	15	16.3	60 (30)	4.5×7.5×5.3	20	2 000	12 600 16 000	10 300 13 000	27 500 37 000	260 350	210 375	1 320 2 130	210 375	1 320 2 130	0.17 0.25	1.6
RA25AL RA25BL	36	5	12.5	48	97.5 115.5	35	35 50	M6×1×8	65.5 83.5	31	12	M6×0.75	6	11	23	24	30 (60)	7×11×9	20	3 900	36 000 43 500	29 200 35 400	72 700 92 900	970 1 240	760 1 240	4 850 7 200	760 1 240	4 850 7 200	0.45 0.80	3.4
RA30AL RA30BL	42	6.5	16	60	110.8 135.4	40	40 60	M8×1.25×11	74 98.6	35.5	14	M6×0.75	7	11	28	28	40 (80)	9×14×12	20	3 900	47 800 58 500	38 900 47 600	93 500 121 000	1 670 2 170	1 140 1 950	7 100 11 500	1 140 1 950	7 100 11 500	0.85 1.1	4.9
RA35AL RA35BL	48	6.5	18	70	123.8 152	50	50 72	M8×1.25×12	83.2 111.4	41.5	15	M6×0.75	8	11	34	31	40 (80)	9×14×12	20	3 900	65 500 82 900	53 300 67 400	129 000 175 000	2 810 3 810	1 800 3 250	11 000 17 800	1 800 3 250	11 000 17 800	1.2 1.7	6.8
RA45AL RA45BL	60	8	20.5	86	154 190	60	60 80	M10×1.5×16	105.4 141.4	52	17	R _c 1/8	10	14	45	38	52.5 (105)	14×20×17	22.5	3 650	114 000 143 000	92 800 116 000	229 000 305 000	6 180 8 240	4 080 7 150	24 000 39 000	4 080 7 150	24 000 39 000	2.5 3.4	10.9
RA55AL RA55BL	70	9	23.5	100	184 234	75	75 95	M12×1.75×18	128 178	61	18	R _c 1/8	11	14	53	43.5	60 (120)	16×23×20	30	3 600	159 000 207 000	129 000 168 000	330 000 462 000	10 200 14 300	7 060 13 600	41 000 72 000	7 060 13 600	41 000 72 000	4.1 5.7	14.6

Notes: 1) Select either the standard dimension for pitch F as shown without parentheses, or the semi-standard dimension as shown inside parentheses. If not specified, the standard dimension for F will be applied.

2) The interchangeable type is available for models RA25 to RA65.
 3) Basic load ratings comply with ISO standards (ISO 14728-1,14728-2).
 C₅₀: Basic dynamic load rating for 50 km rated fatigue life
 C₁₀₀: Basic dynamic load rating for 100 km rated fatigue life

Flanged type (for both tapped and bolt mounting holes)
RA-EM (High load/standard), RA-GM (Super-high load/long)

(1) Reference number for preloaded assembly

RA 35 1000 EM C 2 - P6 3**

Model name: RA 35 1000 EM C 2 -** P6 3
Preload code: 3
Size: 35
Rail length (mm): 1000
Roller slide shape code: EM, GM
Material/surface treatment code: C
Accuracy code: P6
Design serial number: 2
Number of roller slides per rail: 3

(2) Reference number for interchangeable type

RAA 35 EM PH H -F

Roller slide: RAA 35 EM PH H -F
Interchangeable roller slide model code: RAA 35 EM PH H -F
Size: 35
Roller slide shape code: EM, GM
Option code: H, -F
Preload code: H
Accuracy code: PH
Design serial number: 2

R1A 35 1000 L C N - PH Z**

Rail: R1A 35 1000 L C N -** PH Z
Interchangeable rail model code: R1A 35 1000 L C N -** PH Z
Size: 35
Rail length (mm): 1000
Rail shape code: L
Material/surface treatment code: C
Preload code: Z
Accuracy code: PH
Design serial number: 2

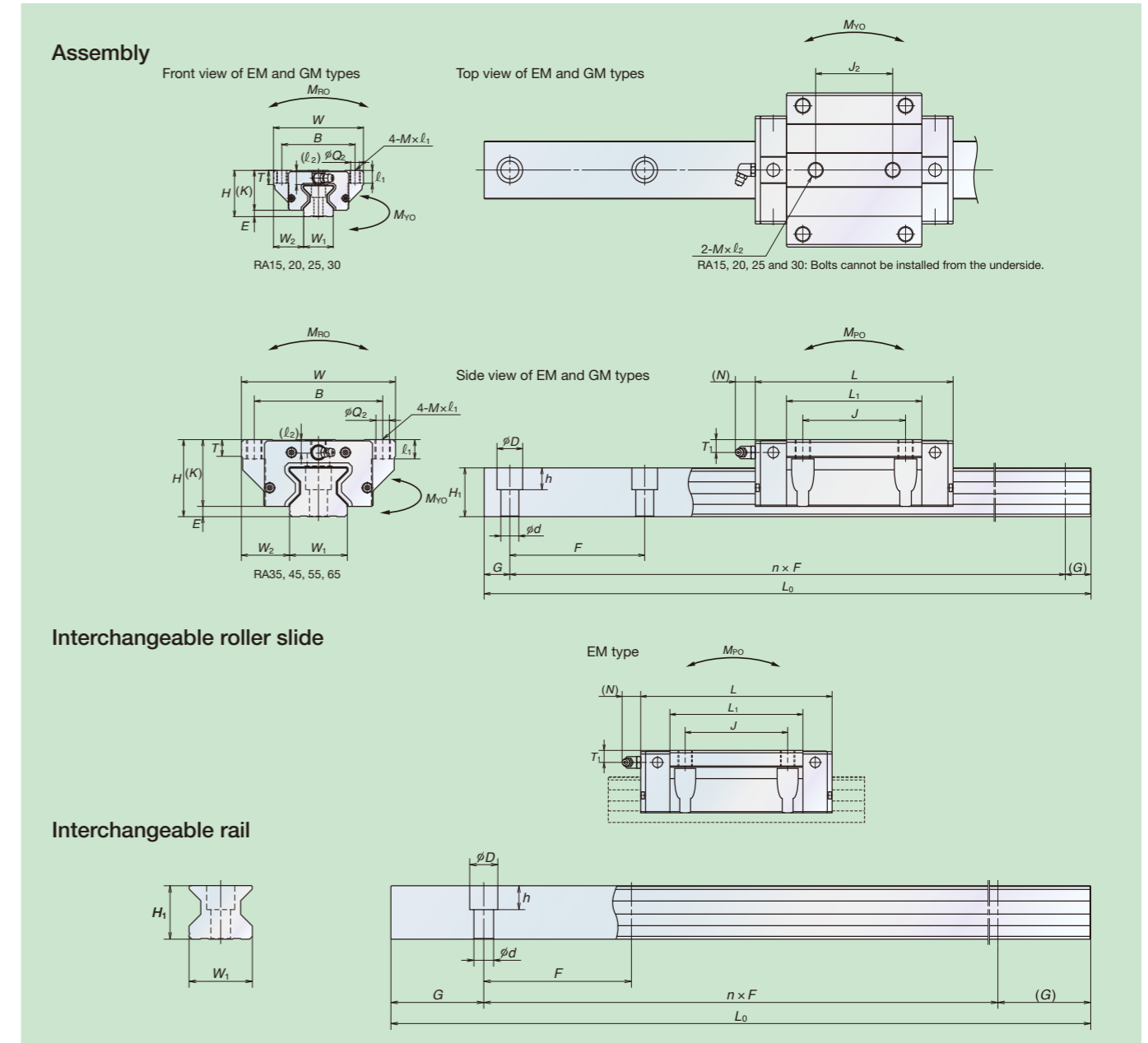

Model No.	Assembly			Roller slide										Rail					Basic load ratings								Weight					
	Height H	E	W ₂	Width W	Length L	Mounting hole					L ₁	K	T	Grease fitting			Width W ₁	Height H ₁	Pitch F	Mounting bolt hole d×D×h	G (reference)	Maximum length L _{0max}	Dynamic		Static C ₀ (N)	Static moment (N·m)				Roller slide (kg)	Rail (kg/m)	
						B	J	J ₂	M × pitch × l ₁ (l ₂)	Q ₂				Hole size	T ₁	N							[50km] C ₅₀ (N)	[100km] C ₁₀₀ (N)		M _{R0}	M _{P0}		M _{V0}			
RA15EM RA15GM	24	4	16	47	70 85.4	38	30	26	M5×0.8×8.5 (6.5)	4.4	44.8 60.2	20	8	φ3	4	3	15	16.3	60 (30)	4.5×7.5×5.3	20	2 000	12 600 16 000	10 300 13 000	27 500 37 000	260 350	210 375	1 320 2 130	210 375	1 320 2 130	0.21 0.28	1.6
RA20EM RA20GM	30	5	21.5	63	86.5 106.3	53	40	35	M6×1×9.5 (8)	5.3	57.5 77.3	25	10	φ3	4	3	20	20.8	60 (30)	6×9.5×8.5	20	3 000	23 600 29 500	19 200 24 000	52 500 70 000	665 890	505 900	3 100 5 000	505 900	3 100 5 000	0.45 0.65	2.6
RA25EM RA25GM	36	5	23.5	70	97.5 115.5	57	45	40	M8×1.25×10 (11)	6.8	65.5 83.5	31	11	M6×0.75	6	11	23	24	30 (60)	7×11×9	20	3 900	36 000 43 500	29 200 35 400	72 700 92 900	970 1 240	760 1 240	4 850 7 200	760 1 240	4 850 7 200	0.80 1.1	3.4
RA30EM RA30GM	42	6.5	31	90	110.8 135.4	72	52	44	M10×1.5×12 (12.5)	8.6	74 98.6	35.5	11	M6×0.75	7	11	28	28	40 (80)	9×14×12	20	3 900	47 800 58 500	38 900 47 600	93 500 121 000	1 670 2 170	1 140 1 950	7 100 11 500	1 140 1 950	7 100 11 500	1.3 1.7	4.9
RA35EM RA35GM	48	6.5	33	100	123.8 152	82	62	52	M10×1.5×13 (7)	8.6	83.2 111.4	41.5	12	M6×0.75	8	11	34	31	40 (80)	9×14×12	20	3 900	65 500 82 900	53 300 67 400	129 000 175 000	2 810 3 810	1 800 3 250	11 000 17 800	1 800 3 250	11 000 17 800	1.7 2.3	6.8
RA45EM RA45GM	60	8	37.5	120	154 190	100	80	60	M12×1.75×15 (10.5)	10.5	105.4 141.4	52	13	R _C 1/8	10	14	45	38	52.5 (105)	14×20×17	22.5	3 650	114 000 143 000	92 800 116 000	229 000 305 000	6 180 8 240	4 080 7 150	24 000 39 000	4 080 7 150	24 000 39 000	3.2 4.3	10.9
RA55EM RA55GM	70	9	43.5	140	184 234	116	95	70	M14×2×18 (13)	12.5	128 178	61	15	R _C 1/8	11	14	53	43.5	60 (120)	16×23×20	30	3 600	159 000 207 000	129 000 168 000	330 000 462 000	10 200 14 300	7 060 13 600	41 000 72 000	7 060 13 600	41 000 72 000	5.4 7.5	14.6
RA65EM RA65GM	90	13	53.5	170	228.4 302.5	142	110	82	M16×2×24 (18.5)	14.6	155.4 229.5	77	22	R _C 1/8	19	14	63	55	75 (150)	18×26×22	35	3 600	259 000 355 000	210 000 288 000	504 000 756 000	19 200 28 700	12 700 28 600	78 500 153 000	12 700 28 600	78 500 153 000	12.2 16.5	22.0

Notes: 1) Select either the standard dimension for pitch F as shown without parentheses, or the semi-standard dimension as shown inside parentheses. If not specified, the standard dimension for F will be applied.

2) The interchangeable type is available for models RA25 to RA65.
3) Basic load ratings comply with ISO standards (ISO 14728-1, 14728-2).

C₅₀: Basic dynamic load rating for 50 km rated fatigue life
C₁₀₀: Basic dynamic load rating for 100 km rated fatigue life

Low profile type (tapped mounting holes)

RB-AL-TL (High load/standard), RB-BL-UL (Super-high load/long)

Reference number for preloaded assembly

RB 35 1000 AL C 2 - P6 3**

Model name	Preload code
Size	3: Z3
Rail length (mm)	Accuracy code
Roller slide shape code: AL, TL, BL, UL	(Without NSK K1): P3, P4, P5, P6 (With NSK K1): K3, K4, K5, K6
Material/surface treatment code	Design serial number
C: Special high carbon steel (NSK standard)	Added to the reference number.
	Number of roller slides per rail

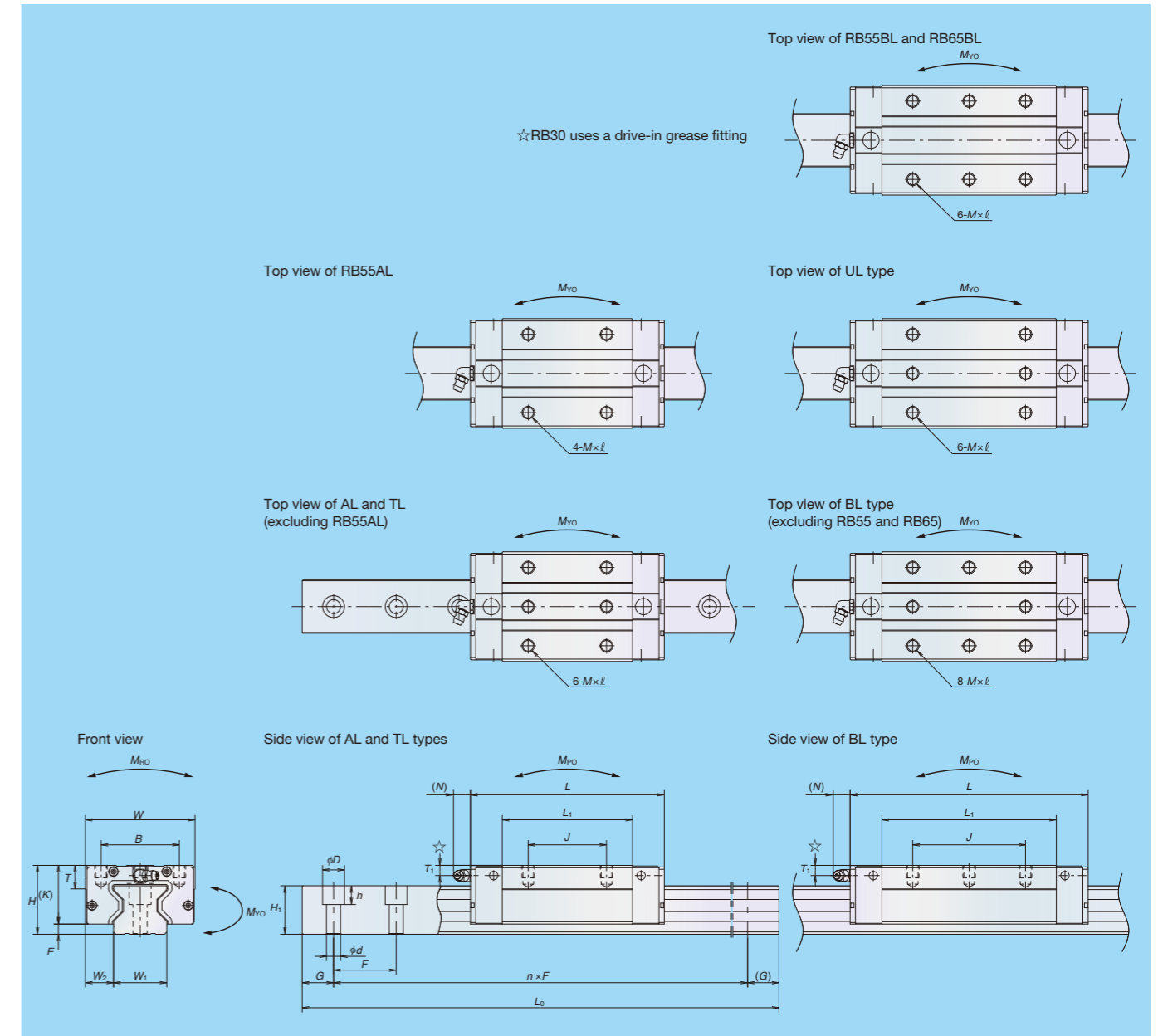

Unit: mm

Model No.	Assembly			Roller slide										Rail					Basic load ratings								Weight				
	Height <i>H</i>	<i>E</i>	<i>W</i> ₂	Width <i>W</i>	Length <i>L</i>	Mounting hole			<i>L</i> ₁	<i>K</i>	<i>T</i>	Grease fitting			Width <i>W</i> ₁	Height <i>H</i> ₁	Pitch <i>F</i>	Mounting bolt hole <i>d</i> × <i>D</i> × <i>h</i>	<i>G</i> (reference)	Maximum length <i>L</i> _{0max}	2) Dynamic		Static <i>C</i> ₀ (N)	<i>M</i> _{R0}	Static moment (N·m)				Roller slide (kg)	Rail (kg/m)	
						<i>B</i>	<i>J</i>	Number of holes				<i>M</i> × pitch × <i>ℓ</i>	Hole size	<i>T</i> ₁							<i>N</i>	[50km] <i>C</i> ₅₀ (N)			[100km] <i>C</i> ₁₀₀ (N)	<i>M</i> _{P0}		<i>M</i> _{Y0}			
RB30AL RB30BL	38	6.5	16	60	110.8 135.4	40	40	6 8	M8×1.25×7	74 98.6	31.5	14	φ3	5	2.6	28	28	40 (80)	9×14×12	20	3 900	47 800 58 500	38 900 47 600	93 500 121 000	1 670 2 170	1 140 1 950	7 100 11 500	1 140 1 950	7 100 11 500	0.71 0.91	4.9
RB35AL RB35BL	44	6.5	18	70	123.8 152	50	50	6 8	M8×1.25×8	83.2 111.4	37.5	15	M6×0.75	6.5	11	34	31	40 (80)	9×14×12	20	3 900	65 500 82 900	53 300 67 400	129 000 175 000	2 810 3 810	1 800 3 250	11 000 17 800	1 800 3 250	11 000 17 800	1.0 1.5	6.8
RB45AL RB45BL	52	8	20.5	86	154 190	60	60	6 8	M10×1.5×10	105.4 141.4	44	17	M6×0.75	6.5	14	45	38	52.5 (105)	14×20×17	22.5	3 650	114 000 143 000	92 800 116 000	229 000 305 000	6 180 8 240	4 080 7 150	24 000 39 000	4 080 7 150	24 000 39 000	1.9 2.6	10.9
RB55AL RB55TL RB55BL RB55UL	63	9	23.5	100	184	65	75	4	M12×1.75×12	128	54	18	R _C 1/8	8.5	14	53	43.5	60 (120)	16×23×20	30	3 600	159 000	129 000	330 000	10 200	7 060	41 000	7 060	41 000	3.4	14.6
234					65	75	6	178		207 000												168 000	462 000	14 300	13 600	72 000	13 600	72 000	4.7		
RB65AL RB65BL RB65UL	75	10	31.5	126	228.4	70	120	6	M16×2×16	155.4	65	22	R _C 1/8	10	14	63	52	75 (150)	18×26×22	35	3 600	259 000	210 000	504 000	19 200	12 700	78 500	12 700	78 500	7.2	20.5
302.5					110	120	6	229.5		355 000												288 000	756 000	28 700	28 600	153 000	28 600	153 000	9.5		

Notes: 1) Select either the standard dimension for pitch *F* as shown without parentheses, or the semi-standard dimension as shown inside parentheses. If not specified, the standard dimension for *F* will be applied.

2) Basic load ratings comply with ISO standards (ISO 14728-1, 14728-2):
*C*₅₀: Basic dynamic load rating for 50 km rated fatigue life
*C*₁₀₀: Basic dynamic load rating for 100 km rated fatigue life

Flanged type (for both tapped and bolt mounting holes)
 RB-EM (High load/standard), RB-GM (Super-high load/long)

Reference number for preloaded assembly

RB 35 1000 EM C 2 - P6 3**

Model name	RB	35	1000	EM	C	2	-**	P6	3	Preload code 3: Z3
Size										Accuracy code (Without NSK K1): P3, P4, P5, P6 (With NSK K1): K3, K4, K5, K6
Rail length (mm)										Design serial number Added to the reference number.
Roller slide shape code: EM, GM										Number of roller slides per rail
Material/surface treatment code C: Special high carbon steel (NSK standard)										

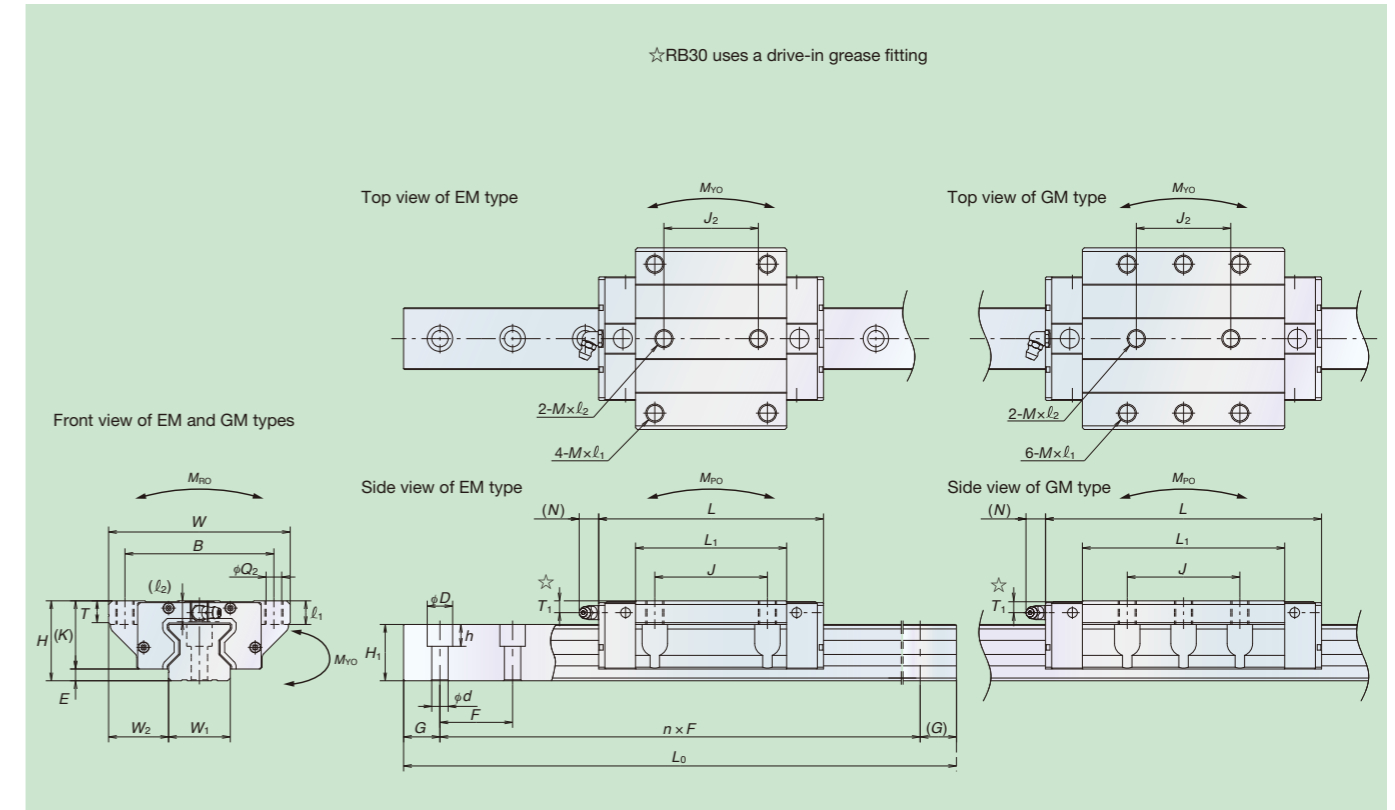

Model No.	Assembly			Roller slide											Rail					Basic load ratings								Weight					
	Height <i>H</i>	<i>E</i>	<i>W</i> ₂	Width <i>W</i>	Length <i>L</i>	Mounting hole						<i>L</i> ₁	<i>K</i>	<i>T</i>	Grease fitting			Width <i>W</i> ₁	Height <i>H</i> ₁	Pitch <i>F</i>	Mounting bolt hole <i>d</i> × <i>D</i> × <i>h</i>	<i>G</i>	Maximum length <i>L</i> _{0max}	2) Dynamic		Static <i>C</i> ₀ (N)	Static moment (N·m)				Roller slide (kg)	Rail (kg/m)	
						<i>B</i>	<i>J</i>	<i>J</i> ₂	Number of holes	<i>M</i> × pitch × <i>l</i> ₁ (<i>l</i> ₂)	<i>Q</i> ₂				Hole size	<i>T</i> ₁	<i>N</i>							[50km] <i>C</i> ₅₀ (N)	[100km] <i>C</i> ₁₀₀ (N)		<i>M</i> _{P0}		<i>M</i> _{V0}				
	<i>H</i>	<i>E</i>	<i>W</i> ₂	<i>W</i>	<i>L</i>	<i>B</i>	<i>J</i>	<i>J</i> ₂	Number of holes	<i>M</i> × pitch × <i>l</i> ₁ (<i>l</i> ₂)	<i>Q</i> ₂	<i>L</i> ₁	<i>K</i>	<i>T</i>	Hole size	<i>T</i> ₁	<i>N</i>	<i>W</i> ₁	<i>H</i> ₁	<i>F</i>	<i>d</i> × <i>D</i> × <i>h</i>	(reference)	<i>L</i> _{0max}	<i>C</i> ₅₀ (N)	<i>C</i> ₁₀₀ (N)	<i>C</i> ₀ (N)	<i>M</i> _{R0}	One slide	Two slides	One slide	Two slides	(kg)	(kg/m)
RB30EM RB30GM	38	6.5	31	90	110.8 135.4	72	52	44	6 8	M10×1.5×12 (8.5)	8.6	74 98.6	31.5	11	φ3	5	2.6	28	28	40 (80)	9×14×12	20	3 900	47 800 58 500	38 900 47 600	93 500 121 000	1 670 2 170	1 140 1 950	7 100 11 500	1 140 1 950	7 100 11 500	1.1 1.5	4.9
RB35EM RB35GM	44	6.5	33	100	123.8 152	82	62	52	6 8	M10×1.5×13 (11.5)	8.6	83.2 111.4	37.5	12	M6×0.75	6.5	11	34	31	40 (80)	9×14×12	20	3 900	65 500 82 900	53 300 67 400	129 000 175 000	2 810 3 810	1 800 3 250	11 000 17 800	1 800 3 250	11 000 17 800	1.5 2.0	6.8
RB45EM RB45GM	52	8	37.5	120	154 190	100	80	60	6 8	M12×1.75×15 (12.5)	10.5	105.4 141.4	44	13	M6×0.75	6.5	14	45	38	52.5 (105)	14×20×17	22.5	3 650	114 000 143 000	92 800 116 000	229 000 305 000	6 180 8 240	4 080 7 150	24 000 39 000	4 080 7 150	24 000 39 000	2.5 3.4	10.9
RB55EM RB55GM	63	9	43.5	140	184 234	116	95	70	6 8	M14×2×18 (18)	12.5	128 178	54	15	R _C 1/8	8.5	14	53	43.5	60 (120)	16×23×20	30	3 600	159 000 207 000	129 000 168 000	330 000 462 000	10 200 14 300	7 060 13 600	41 000 72 000	7 060 13 600	41 000 72 000	4.7 6.6	14.6
RB65EM RB65GM	75	10	53.5	170	228.4 302.5	142	110	82	6 8	M16×2×24 (21)	14.6	155.4 229.5	65	15	R _C 1/8	10	14	63	52	75 (150)	18×26×22	35	3 600	259 000 355 000	210 000 288 000	504 000 756 000	19 200 28 700	12 700 28 600	78 500 153 000	12 700 28 600	78 500 153 000	9.7 13.2	20.5

Notes: 1) Select either the standard dimension for pitch *F* as shown without parentheses or the semi-standard dimension as shown inside parentheses. If not specified, the standard dimension for *F* will be applied.

2) Basic load ratings comply with ISO standards (ISO 14728-1,14728-2):
*C*₅₀: Basic dynamic load rating for 50 km rated fatigue life
*C*₁₀₀: Basic dynamic load rating for 100 km rated fatigue life

Unit: mm